



2023



**CATALOG
STANDARD TOOLS**
СТАНДАРТНЫЙ ИНСТРУМЕНТ

**DNIPROVSKY
SPECIAL TOOLS PLANT**
Днепро́вский завод специнструмента



**ДНЕПРОВСКИЙ
ЗАВОД
СПЕЦИНСТРУМЕНТА**

**DNEPROVSKY
SPECIAL TOOLS
PLANT**



Наша философия – устойчивое развитие.
Качество. Лидерство. Эти основные
ценности предприятия «ДЗС» определяют
общую стратегию долгосрочного развития.

Our philosophy - sustainable development.
Quality. Leadership. These main values of
“DSTP” determine the total strategy of long-
term development.





We cover
credibility

QSCert, spol. s r. o.
Certification Body of Management Systems
Residence address: Klimentěska 52, Nové Město, 110 00 Prague 1, Czech Republic
Postal address: E. P. Vojanického 1, 960 01 Zvolen, Slovak Republic

выдал настоящий

СЕРТИФИКАТ

как свидетельство регистрации системы менеджмента качества компании

ООО "Днепровский завод специнструмента"

ул. Строителей, 34, корп. 94В, г. Днепр, 49000, Украина

разработанной и внедренной в соответствии с требованиями международного стандарта

ISO 9001:2015

Компания применяет указанные требования в отношении следующих видов деятельности:

Изготовление металлорежущего инструмента и оснастки для предприятий металлургической отрасли, для производства труб, железнодорожных колес, рельсов, вагонов, подшипников, для горнодобывающей промышленности; производство промышленных ножей

Сертифицированная СМК функционирует по адресу: ул. Строителей, 34, корп. 94В, г. Днепр, 49000, Украина

Результаты, представленные в отчете об аудите № R 075/17/06, подтверждают, что система менеджмента качества полностью соответствует требованиям вышеуказанного стандарта.

Сертификат № Q-5706/17
Дата первой сертификации: 20.12.2010
Выдан: 11.04.2017
Действителен до: 08.01.2020



S 3177

Данный сертификат считается действительным лишь при условии сохранения его в списке действующих сертификатов, опубликованном на сайте www.qscert.com



Ing. Marcel Slúch
Генеральный директор





РУС

ООО «Днепровский завод специнструмента» – крупнейшее предприятие СНГ, специализирующееся на производстве металлорежущего инструмента и оснастки для предприятий металлургической, железнодорожной и трубной промышленности. В течение многих лет наш завод обеспечивает предприятия Украины, Польша, Чехия, Турция, Грузия, Азербайджан и Германии стандартным и специальным металлорежущим инструментом европейского качества. Среднесписочный штат работников предприятия – 120 чел.

Основные группы товарной продукции предприятия:

- инструмент с механическим креплением пластин (державки, фрезы, сверла, блоки и пр.)
- напайной инструмент
- цельный инструмент
- ножи для пресс-ножниц
- пневмоинструмент
- клейма
- прочий инструмент и оснастка

Предприятие изготавливает и поставляет металлорежущий инструмент по чертежам, техническим заданиям применительно к технологическому процессу предприятия заказчика и в соответствии с собственными техническими условиями.

ООО «ДЗС» располагает парком оборудования для полного технологического цикла производства инструмента:

- ленточнопильные станки,
- токарные и универсально-фрезерные станки,
- координатно-расточные станки,
- плоско- и круглошлифовальные станки,
- 3- и 5-координатные обрабатывающие центры с ЧПУ
- токарные станки с ЧПУ
- установки ТВЧ
- участок для термической обработки, в т.ч. соляные ванны
- установки для галтовки и пескоструйной обработки,
- ванны для химического и электрохимического покрытия.

ENG

“Dneprovsky special tools plant” LLC is the biggest company in the CIS, specializing in production of metal-cutting tools and machinery parts for metallurgical, railway and pipe industries. For many years, our plant provides companies of Ukraine, Poland, Czech Republic, Turkey, Georgia, Azerbaijan and Germany with standard and special metal cutting tools of European quality. Average number-staff of employees is 200 people.

The main product groups of the company:

- tools with mechanical mounting of carbide inserts. (holders, boring cutters, drills, blocks...)
- brazed tools
- solid tools (HSS and tool steels)
- shear blades
- pneumatic tools
- stamping tools
- other instruments and equipment

The plant manufactures metal cutting tools according to samples, drawings and technical tasks, in relation to the production process of the customer and its technical specifications.

“DZS” LLC operates machinery park for the full production cycle of tools:

- band saw machines,
- turning and universal milling machines,
- precision-boring machines,
- surface-, face and cylindrical grinding machines,
- 3- and 5-axis Machining Centers with CPU
- turning Machining Centers with CPU
- brazing machines
- area for heat treatment and salt baths,
- vibration finishing and sand blasting machines,

Заготовительный участок
Rough machining area



Участок шлифовальных станков
Sector of grinding machines



Термический участок
Heat treatment area



Участок финишной обработки
Finishing area



Участок станков с ЧПУ
Sector of CPU machines



Токарные державки

C-System.....	13
D-System.....	14
M-System.....	22
P-System.....	25
S-System.....	36
Отрезные державки.....	46
Резьбовые державки.....	50
Комплектующие.....	51
Техническая часть.....	58

Сверла.....	69
-------------	----

Фрезы.....	71
------------	----

Turning toolholders

C-System.....	13
D-System.....	14
M-System.....	22
P-System.....	25
S-System.....	36
Cutoff toolholders.....	46
Threading toolholders.....	50
Spare parts.....	51
Technical part.....	58

Drills.....	69
-------------	----

Mills.....	71
------------	----

Токарные державки | Turning toolholders



Наружная обработка

External turning

1		2		3		4	
Способ крепления Type of clamping		Форма пластины Shape of insert		Главный угол в плане Entering angle		Задний угол пластины Back angle of insert	
C		S		A			$\alpha_n=0^\circ$
D		C		B			$\alpha_n=7^\circ$
P		T		C			$\alpha_n=11^\circ$
M		D		D			
S		R		E			
		K		F			
		W		G			
		V		H			
		L		J			
		X		K			
			Специальный Special	L			
				M			
				N			
				P			
				Q			
				R			
				S			
				S			
				T			
				U			
				V			
				W			
				X			
				Y			
				Z			

1 2 3 4 5 6 7 8 9 10
P C L N R - 32 25 L 12 -

6					
Высота державки [мм] Height of holder (mm)					
08	10	12	16	20	25
32	38	40	45	50	60

7					
Ширина державки [мм] Width of holder (mm)					
08	10	12	16	20	25
32	38	40	45	50	60

8	
Общая длина Total length	
	l_1 [mm]
D	60
E	70
F	80
H	100
J	110
K	125
L	140
M	150
N	160
P	170
Q	180
R	200
S	250
T	300
U	350
V	400
W	450
X	Специальный Special 25,40
Y	500

9									
Размер пластины Size of insert									
	S	C	E	D	V	K	W	T	R
d [mm]									
3,97					07				06
6,00									
6,35		06		07	11			11	
7,94		08	08		13				
8,00								08	
9,525	09	09		11	16	19	06	16	
10,00									10
12,00									12
12,70	12	12		15			08	22	12
15,875	15	16						27	15
16,00									16
19,05	19	19							19
20,00									20
25,00									25
25,40	25	25							25
38,10	38								

10	
Обозначение производителя [мм] Producer identification (mm)	



Внутренняя обработка

Internal turning

1		2				
Исполнение державки Holder make		Диаметр державки [мм] Holder diameter (mm)				
S	Стальная державка Steel holder	08	10	12	16	20
		25	32	40	50	60
A	Стальная державка с отверстием для подвода СОЖ Steel holder with hole for coolant					

1	2	3	4	5	6	7	8	9	10	
A	40	T	-	P	C	L	N	L	12	-

3	4	5	6																																																																																																																																																																																														
Общая длина Total length	Способ крепления Type of clamping	Форма пластины Form of insert	Главный угол в плане Entering angle																																																																																																																																																																																														
<table border="1"> <tr><td></td><td>l_1 [mm]</td></tr> <tr><td>D</td><td>60</td></tr> <tr><td>E</td><td>70</td></tr> <tr><td>F</td><td>80</td></tr> <tr><td>H</td><td>100</td></tr> <tr><td>J</td><td>110</td></tr> <tr><td>K</td><td>125</td></tr> <tr><td>L</td><td>140</td></tr> <tr><td>M</td><td>150</td></tr> <tr><td>N</td><td>160</td></tr> <tr><td>P</td><td>170</td></tr> <tr><td>Q</td><td>180</td></tr> <tr><td>R</td><td>200</td></tr> <tr><td>S</td><td>250</td></tr> <tr><td>T</td><td>300</td></tr> <tr><td>U</td><td>350</td></tr> <tr><td>V</td><td>400</td></tr> <tr><td>W</td><td>450</td></tr> <tr><td>X</td><td>Spec.</td></tr> <tr><td>Y</td><td>500</td></tr> </table>		l_1 [mm]	D	60	E	70	F	80	H	100	J	110	K	125	L	140	M	150	N	160	P	170	Q	180	R	200	S	250	T	300	U	350	V	400	W	450	X	Spec.	Y	500	<table border="1"> <tr><td>C</td><td></td></tr> <tr><td>D</td><td></td></tr> <tr><td>P</td><td></td></tr> <tr><td>M</td><td></td></tr> <tr><td>S</td><td></td></tr> </table>	C		D		P		M		S		<table border="1"> <tr><td>S</td><td></td><td>C</td><td></td></tr> <tr><td>T</td><td></td><td>D</td><td></td></tr> <tr><td>R</td><td></td><td>K</td><td></td></tr> <tr><td>W</td><td></td><td>V</td><td></td></tr> <tr><td>L</td><td></td><td>X</td><td>Специальный Special</td></tr> </table>	S		C		T		D		R		K		W		V		L		X	Специальный Special	<table border="1"> <tr><td>A</td><td></td><td>B</td><td></td><td>C</td><td></td><td>D</td><td></td><td>D</td><td></td></tr> <tr><td>90°</td><td></td><td>75°</td><td></td><td>90°</td><td></td><td>45°</td><td></td><td></td><td></td></tr> <tr><td>E</td><td></td><td>F</td><td></td><td>G</td><td></td><td>H</td><td></td><td>J</td><td></td></tr> <tr><td>60°</td><td></td><td>90°</td><td></td><td>90°</td><td></td><td>107°30'</td><td></td><td>93°</td><td></td></tr> <tr><td>K</td><td></td><td>L</td><td></td><td>M</td><td></td><td>N</td><td></td><td>P</td><td></td></tr> <tr><td>75°</td><td></td><td>95°</td><td></td><td>50°</td><td></td><td>62°30'</td><td></td><td>117°30'</td><td></td></tr> <tr><td>Q</td><td></td><td>R</td><td></td><td>S</td><td></td><td>S</td><td></td><td>T</td><td></td></tr> <tr><td>107°30'</td><td></td><td>75°</td><td></td><td>45°</td><td></td><td></td><td></td><td>60°</td><td></td></tr> <tr><td>U</td><td></td><td>V</td><td></td><td>W</td><td></td><td>X</td><td></td><td>Y</td><td></td></tr> <tr><td>93°</td><td></td><td>72°30'</td><td></td><td>60°</td><td></td><td></td><td></td><td>85°</td><td></td></tr> <tr><td>Z</td><td></td><td></td><td></td><td></td><td></td><td></td><td></td><td></td><td></td></tr> <tr><td>K</td><td></td><td></td><td></td><td></td><td></td><td></td><td></td><td></td><td></td></tr> </table>	A		B		C		D		D		90°		75°		90°		45°				E		F		G		H		J		60°		90°		90°		107°30'		93°		K		L		M		N		P		75°		95°		50°		62°30'		117°30'		Q		R		S		S		T		107°30'		75°		45°				60°		U		V		W		X		Y		93°		72°30'		60°				85°		Z										K									
	l_1 [mm]																																																																																																																																																																																																
D	60																																																																																																																																																																																																
E	70																																																																																																																																																																																																
F	80																																																																																																																																																																																																
H	100																																																																																																																																																																																																
J	110																																																																																																																																																																																																
K	125																																																																																																																																																																																																
L	140																																																																																																																																																																																																
M	150																																																																																																																																																																																																
N	160																																																																																																																																																																																																
P	170																																																																																																																																																																																																
Q	180																																																																																																																																																																																																
R	200																																																																																																																																																																																																
S	250																																																																																																																																																																																																
T	300																																																																																																																																																																																																
U	350																																																																																																																																																																																																
V	400																																																																																																																																																																																																
W	450																																																																																																																																																																																																
X	Spec.																																																																																																																																																																																																
Y	500																																																																																																																																																																																																
C																																																																																																																																																																																																	
D																																																																																																																																																																																																	
P																																																																																																																																																																																																	
M																																																																																																																																																																																																	
S																																																																																																																																																																																																	
S		C																																																																																																																																																																																															
T		D																																																																																																																																																																																															
R		K																																																																																																																																																																																															
W		V																																																																																																																																																																																															
L		X	Специальный Special																																																																																																																																																																																														
A		B		C		D		D																																																																																																																																																																																									
90°		75°		90°		45°																																																																																																																																																																																											
E		F		G		H		J																																																																																																																																																																																									
60°		90°		90°		107°30'		93°																																																																																																																																																																																									
K		L		M		N		P																																																																																																																																																																																									
75°		95°		50°		62°30'		117°30'																																																																																																																																																																																									
Q		R		S		S		T																																																																																																																																																																																									
107°30'		75°		45°				60°																																																																																																																																																																																									
U		V		W		X		Y																																																																																																																																																																																									
93°		72°30'		60°				85°																																																																																																																																																																																									
Z																																																																																																																																																																																																	
K																																																																																																																																																																																																	

7	8	9																																																																																																																																																																																														
Задний угол пластины Back angle of insert	Направление резания Cutting direction	Размер пластины Size of insert																																																																																																																																																																																														
<table border="1"> <tr><td>N</td><td>C</td><td>P</td></tr> <tr><td>$\alpha_n=0^\circ$</td><td>$\alpha_n=7^\circ$</td><td>$\alpha_n=11^\circ$</td></tr> </table>	N	C	P	$\alpha_n=0^\circ$	$\alpha_n=7^\circ$	$\alpha_n=11^\circ$	<table border="1"> <tr><td>R</td><td></td></tr> <tr><td>L</td><td></td></tr> </table>	R		L		<table border="1"> <tr> <td></td> <td>S</td><td>C</td><td>E</td><td>D</td><td>V</td><td>K</td><td>W</td><td>T</td><td>R</td> </tr> <tr> <td>d [mm]</td> <td></td><td></td><td></td><td></td><td></td><td></td><td></td><td></td><td></td> </tr> <tr><td>3,97</td><td></td><td></td><td></td><td></td><td>07</td><td></td><td>02</td><td>06</td><td></td></tr> <tr><td>5,56</td><td></td><td></td><td></td><td></td><td></td><td></td><td></td><td>09</td><td></td></tr> <tr><td>6,00</td><td></td><td></td><td></td><td></td><td></td><td></td><td></td><td></td><td>06</td></tr> <tr><td>6,35</td><td></td><td>06</td><td>06</td><td>07</td><td>11</td><td></td><td></td><td>11</td><td></td></tr> <tr><td>7,94</td><td></td><td>08</td><td>08</td><td></td><td>13</td><td></td><td></td><td></td><td></td></tr> <tr><td>8,00</td><td></td><td></td><td></td><td></td><td></td><td></td><td></td><td></td><td>08</td></tr> <tr><td>9,525</td><td>09</td><td>09</td><td></td><td>11</td><td>16</td><td>19</td><td>06</td><td>16</td><td></td></tr> <tr><td>10,00</td><td></td><td></td><td></td><td></td><td></td><td></td><td></td><td></td><td>10</td></tr> <tr><td>12,00</td><td></td><td></td><td></td><td></td><td></td><td></td><td></td><td></td><td>12</td></tr> <tr><td>12,70</td><td>12</td><td>12</td><td></td><td>15</td><td></td><td></td><td>08</td><td>22</td><td>12</td></tr> <tr><td>15,875</td><td>15</td><td>16</td><td></td><td></td><td></td><td></td><td></td><td>27</td><td>15</td></tr> <tr><td>16,00</td><td></td><td></td><td></td><td></td><td></td><td></td><td></td><td></td><td>16</td></tr> <tr><td>19,05</td><td>19</td><td>19</td><td></td><td></td><td></td><td></td><td></td><td></td><td>19</td></tr> <tr><td>20,00</td><td></td><td></td><td></td><td></td><td></td><td></td><td></td><td></td><td>20</td></tr> <tr><td>25,00</td><td></td><td></td><td></td><td></td><td></td><td></td><td></td><td></td><td>25</td></tr> <tr><td>25,40</td><td>25</td><td>25</td><td></td><td></td><td></td><td></td><td></td><td></td><td>25</td></tr> </table>		S	C	E	D	V	K	W	T	R	d [mm]										3,97					07		02	06		5,56								09		6,00									06	6,35		06	06	07	11			11		7,94		08	08		13					8,00									08	9,525	09	09		11	16	19	06	16		10,00									10	12,00									12	12,70	12	12		15			08	22	12	15,875	15	16						27	15	16,00									16	19,05	19	19							19	20,00									20	25,00									25	25,40	25	25							25
N	C	P																																																																																																																																																																																														
$\alpha_n=0^\circ$	$\alpha_n=7^\circ$	$\alpha_n=11^\circ$																																																																																																																																																																																														
R																																																																																																																																																																																																
L																																																																																																																																																																																																
	S	C	E	D	V	K	W	T	R																																																																																																																																																																																							
d [mm]																																																																																																																																																																																																
3,97					07		02	06																																																																																																																																																																																								
5,56								09																																																																																																																																																																																								
6,00									06																																																																																																																																																																																							
6,35		06	06	07	11			11																																																																																																																																																																																								
7,94		08	08		13																																																																																																																																																																																											
8,00									08																																																																																																																																																																																							
9,525	09	09		11	16	19	06	16																																																																																																																																																																																								
10,00									10																																																																																																																																																																																							
12,00									12																																																																																																																																																																																							
12,70	12	12		15			08	22	12																																																																																																																																																																																							
15,875	15	16						27	15																																																																																																																																																																																							
16,00									16																																																																																																																																																																																							
19,05	19	19							19																																																																																																																																																																																							
20,00									20																																																																																																																																																																																							
25,00									25																																																																																																																																																																																							
25,40	25	25							25																																																																																																																																																																																							
10																																																																																																																																																																																																
Обозначение изготовителя Producer identification (mm)																																																																																																																																																																																																
X	Специальное исполнение державки Special make of holder																																																																																																																																																																																															
.																																																																																																																																																																																																
87	Значение угла в плане k для реза типа "Z" Meaning of cutting edge angle k for cutter of type "Z"																																																																																																																																																																																															
90																																																																																																																																																																																																
93																																																																																																																																																																																																
.																																																																																																																																																																																																

Тип С – Прижим прихватом

Type C – Pressing by top clamp

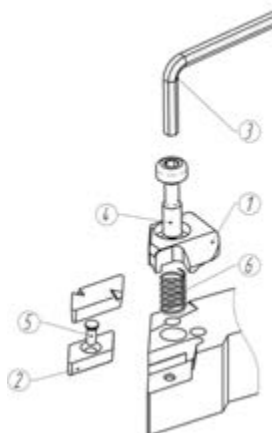

- 1 - Прихват
- Clamp
- 2 - Опорная пластина
- Shim
- 3 - Ключ винта прихвата
- Key of clamp screw
- 4 - Винт прихвата
- Clamp screw
- 5 - Винт опорной пластины
- Shim screw
- 6 - Пружина
- Spring

Тип D – Прижим прихватом повышенной жесткости

Type D – Double clamping system



- 1 - Прихват
- Clamp
- 2 - Ключ винта прихвата
- Key of clamp screw
- 3 - Опорная пластина
- Shim
- 4 - Винт опорной пластины
- Shim screw
- 5 - Ключ винта опорной пластины
- Shim key
- 6 - Пружина
- Spring
- 7 - Винт прихвата
- Clamp screw

Тип М – Прижим прихватом на штифте

Type M – Pressing by clamp on a pin



- 1 - Опорная пластина
- Shim
- 2 - Штифт (цапфа)
- Pin
- 3 - Прихват
- Clamp
- 4 - Винт прихвата
- Clamp screw
- 5 - Ключ винта прихвата
- Key of clamp screw

Тип М – Прижим клин-прихватом

Type M - Pressing by wedge-clamp



- 1 - Винт прихвата
- Clamp screw
- 2 - Ключ винта прихвата
- Key of clamp screw
- 3 - Пружина
- Spring
- 4 - Опорная пластина
- Shim
- 5 - Штифт (цапфа)
- Pin
- 6 - Клин-прихват
- Wedge-clamp

Тип Р – Прижим рычагом

Type P- Pressing by lever

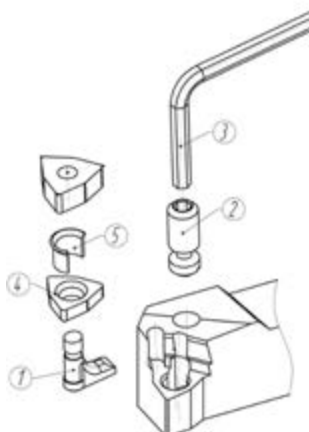

- 1 - Рычаг
- Lever
- 2 - Винт рычага
- Lever screw
- 3 - Ключ винта
- Key screw
- 4 - Опорная пластина
- Shim
- 5 - Втулка
- Tubular rivet

Тип S – Прижим винтом

Type S – Fixation by screw

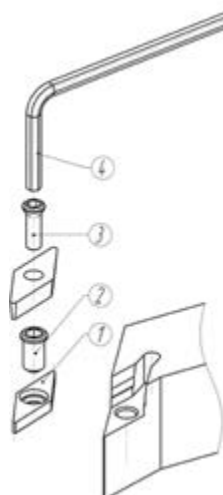

- 1 - Опорная пластина
- Shim
- 2 - Винт опорной пластины
- Shim screw
- 3 - Винт зажимной
- Screw clamp
- 4 - Ключ винта
- Key screw

СКJNR/L

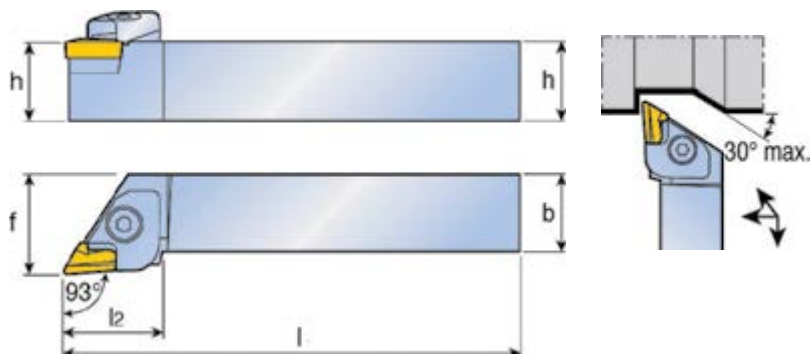
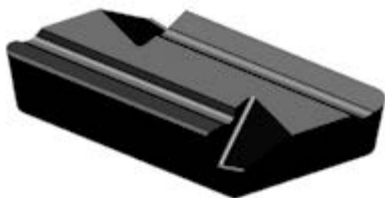

Державка Holder	Размеры Dimensions				Комплектация Spare parts							Режущая пластина Cutting insert
	h	b	f	l	Прижим Clamp	Пластина опорная Shim	Винт опорной пластины Shim screw	Винт прижима Clamp screw	Пружина Spring	Ключ прихвата Key of clamp screw	Ключ винта подкладной Key of shim screw	
СКJNR/L 2020 K16	20	20	25	125	CL 16KR/L	KNN 190412 R/L	M3	DLS 5	DSP 5	H5.0	H2.5	KNUX 1604** R/L 1604 ** R/L
2525 M16	25	25	32	150	CL 16KR/L	KNN 190412 R/L	M3	DLS 5	DSP 5	H5.0	H2.5	
3225 P16	32	25	32	170	CL 16KR/L	KNN 190412 R/L	M3	DLS 5	DSP 5	H5.0	H2.5	
3232 P16	32	32	40	170	CL 16KR/L	KNN 190412 R/L	M3	DLS 5	DSP 5	H5.0	H2.5	
4040 R16	40	40	50	200	CL 16KR/L	KNN 190412 R/L	M3	DLS 5	DSP 5	H5.0	H2.5	
2525 M19	25	25	32	150	CL 19KR/L	741-1904-1/2	M3	DLS 5	DSP 5	H5.0	H2.5	KNUX 1906 R/L
3225 P19	32	25	32	170	CL 19KR/L	741-1904-1/2	M3	DLS 5	DSP 5	H5.0	H2.5	
3232 R19	32	32	40	170	CL 19KR/L	741-1904-1/2	M3	DLS 5	DSP 5	H5.0	H2.5	
4040 R19	40	40	50	200	CL 19KR/L	741-1904-1/2	M3	DLS 5	DSP 5	H5.0	H2.5	

CRDCN

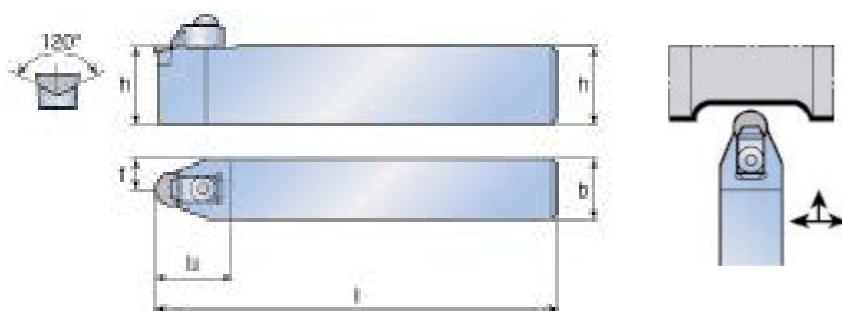

Державка Holder	Размеры Dimensions				Комплектация Spare parts							Режущая пластина Cutting insert
	h	b	f	l	Прижим Clamp	Пластина опорная Shim	Винт опорной пластины Shim screw	Винт прижима Clamp screw	Пружина Spring	Ключ прихвата Key of clamp screw	Ключ винта подкладной Key of shim screw	
CRDCN 3225 P06-A	32	25	12.5	170	CL 06	CX 06	M2.5	M3*10	-	H2.5	-	RCGX 0606
3225 P09-A	32	25	12.5	170	CL 09	CX 09	M3.5	DLS 4	-	H4.0	-	RCGX 0907
3225 P12-A	32	25	12.5	170	CL 12	CX 12	M5	DLS 5	-	H5.0	-	RCGX 1207

DCKNR/L

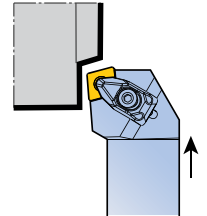
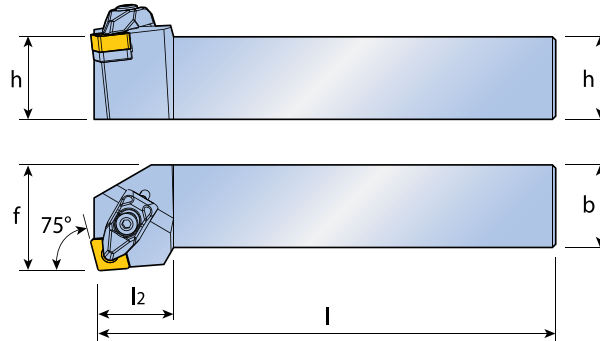

Державка Holder	Размеры Dimensions				Комплектация Spare parts							Режущая пластина Cutting insert	
	h	b	f	l	Винт опорной пластины Shim screw	Пластина опорная Shim	Прихват Clamp	Винт прихвата Clamp screw	Пружина Spring	Ключ винта прихвата Key of clamp screw	Ключ винта опорной пластины Key of shim screw		
DCKNR/L	2020 K12	20	20	25	125	M3	731-1203	DLM 4	DLS 4	DSP 4	H3.0	H2.0	CNM.1204..
	2525 M12	25	25	32	150	M3	731-1203	DLM 4	DLS 4	DSP 4	H3.0	H2.0	CNM.1204..
	3225 P12	32	25	32	170	M3	731-1203	DLM 4	DLS 4	DSP 4	H3.0	H2.0	CNM.1204..
	3232 P16	32	32	40	170	M5	731-1604	DLM 4	DLS 4	DSP 4	H3.0	H3.0	CNM.1606..
	3232 P19	32	32	40	170	M5	731-1904	DLM 6	DLS 5	DSP 5	H4.0	H3.0	CNM.1906..
	4040 S19	40	40	50	250	M5	731-1904	DLM 6	DLS 5	DSP 5	H4.0	H3.0	CNM.1906..

DCLNR/L

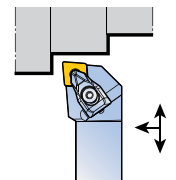
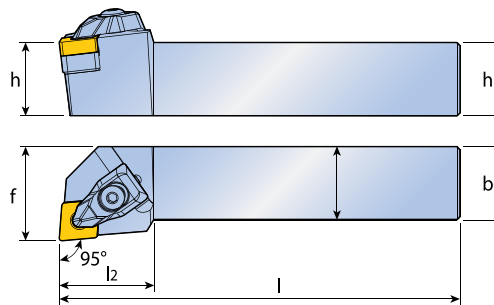
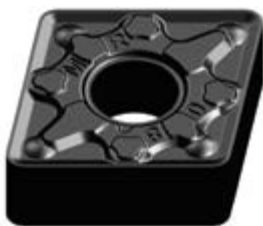

Державка Holder	Размеры Dimensions				Комплектация Spare parts							Режущая пластина Cutting insert	
	h	b	f	l	Винт опорной пластины Shim screw	Пластина опорная Shim	Прихват Clamp	Винт прихвата Clamp screw	Пружина Spring	Ключ винта прихвата Key of clamp screw	Ключ винта опорной пластины Key of shim screw		
DCLNR/L	1616 H09	16	16	20	100	M3	731-0903	DLM 3	DLS 3	DSP 3	H2.5	H2.0	CNM.0903..
	2020 K09	20	20	25	125	M3	731-0903	DLM 3	DLS 3	DSP 3	H2.5	H2.0	CNM.0903..
	2525 M09	25	25	32	150	M3	731-0903	DLM 3	DLS 3	DSP 3	H2.5	H2.0	CNM.0903..
	2020 K12	20	20	25	125	M3	731-1203	DLM 4	DLS 4	DSP 4	H3.0	H2.0	CNM.1204..
	2525 M12	25	25	32	150	M3	731-1203	DLM 4	DLS 4	DSP 4	H3.0	H2.0	CNM.1204..
	3225 P12	32	25	32	170	M3	731-1203	DLM 4	DLS 4	DSP 4	H3.0	H2.0	CNM.1204..
	2525 M16	25	25	32	150	M5	731-1604	DLM 4	DLS 4	DSP 4	H4.0	H3.0	CNM.1606..
	3225 P16	32	25	32	170	M5	731-1604	DLM 4	DLS 4	DSP 4	H4.0	H3.0	CNM.1606..
	3232 P16	32	32	40	170	M5	731-1604	DLM 4	DLS 4	DSP 4	H4.0	H3.0	CNM.1606..
	3232 P19	32	32	40	170	M5	731-1904	DLM 6	DLS 5	DSP 5	H4.0	H3.0	CNM.1906..
	4040 R19	40	40	50	200	M5	731-1904	DLM 6	DLS 5	DSP 5	H4.0	H3.0	CNM.1906..

DDJNR/L

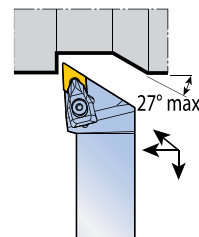
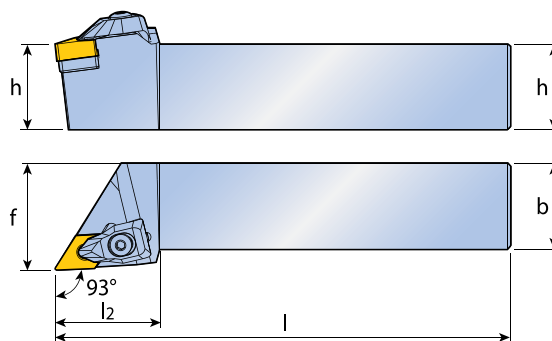

Державка Holder	Размеры Dimensions				Комплектация Spare parts								Режущая пластина Cutting insert
	h	b	f	l	Винт опорной пластины Shim screw	Пластина опорная Shim	Прихват Clamp	Винт прихвата Clamp screw	Пружина Spring	Ключ винта прихвата Key of clamp screw	Ключ винта опорной пластины Key of shim screw		
DDJNR/L 2020 K11	20	20	25	125	M3	781-1103	DLM 3	DLS 3	DSP 3	H2.5	H2.5	DNM. 1104..	
2020 K15	20	20	25	125	SO 40100	781-1503	DLM 4	DLS 4	DSP 4	H3.0	H2.5	DNM. 1506..	
2525 M11	25	25	32	150	M3	781-1103	DLM 3	DLS 3	DSP 3	H2.5	H2.5	DNM. 1104..	
2525 M15	25	25	32	150	SO 40100	781-1503 781-1504	DLM 4	DLS 4	DSP 4	H3.0	H2.5	DNM. 1506..	
3225 P15	32	25	32	170	SO 40100	781-1503 781-1504	DLM 4	DLS 4	DSP 4	H3.0	H2.5	DNM. 1506..	
3232 P15	32	32	40	170	SO 40100	781-1503 781-1504	DLM 4	DLS 4	DSP 4	H3.0	H2.5	DNM. 1506..	

DDNNR/L

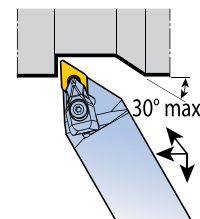
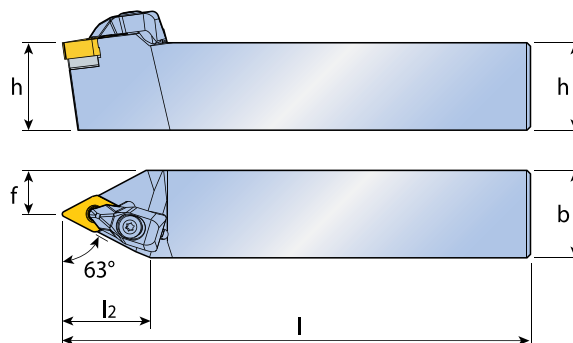

Державка Holder	Размеры Dimensions				Комплектация Spare parts								Режущая пластина Cutting insert
	h	b	f	l	Винт опорной пластины Shim screw	Пластина опорная Shim	Прихват Clamp	Винт прихвата Clamp screw	Пружина Spring	Ключ винта прихвата Key of clamp screw	Ключ винта опорной пластины Key of shim screw		
DDNNR/L 2020 K11	20	20	10	125	M3	781-1103	DLM 3	DLS 3	DSP 3	H2.5	H3.0	DNM. 1104..	
2525 M11	25	25	13	150	M3	781-1103	DLM 3	DLS 3	DSP 3	H2.5	H3.0	DNM. 1104..	
2525 M15	25	25	13	150	SO 40100	781-1503	DLM 4	DLS 4	DSP 4	H3.0	H3.0	DNM. 1506..	

DSBNR/L

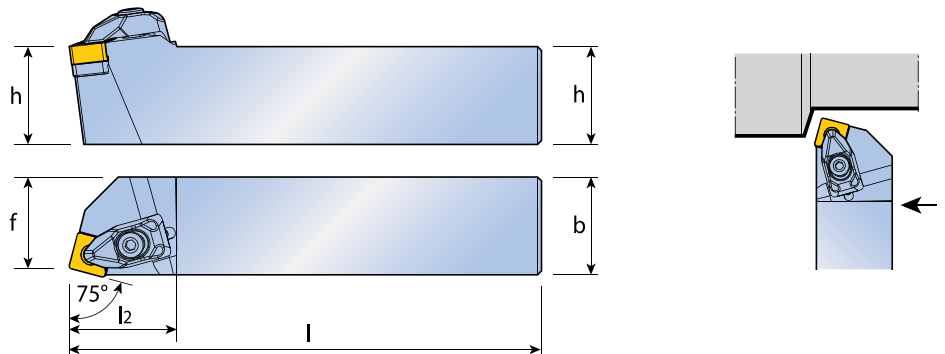

Державка Holder	Размеры Dimensions				Комплектация Spare parts								Режущая пластина Cutting insert
	h	b	f	l	Винт опорной пластины Shim screw	Пластина опорная Shim	Прихват Clamp	Винт прихвата Clamp screw	Пружина Spring	Ключ винта прихвата Key of clamp screw	Ключ винта опорной пластины Key of shim screw		
DSBNR/L 2020 K12	20	20	17	125	M3	721-1203	DLM 4	DLS 4	DSP 4	H3.0	H2.0	SNM.1204..	
2525 M12	25	25	22	150	M3	721-1203	DLM 4	DLS 4	DSP 4	H3.0	H2.0	SNM.1204..	
3225 P15	32	25	22	170	M5	721-1504	DLM 4	DLS 4	DSP 4	H3.0	H3.0	SNM.1506..	
3232 P19	32	32	27	170	M5	721-1904	DLM 6	DLS 5	DSP 5	H4.0	H3.0	SNM.1906..	
4040 R19	40	40	35	200	M5	721-1904	DLM 6	DLS 5	DSP 5	H4.0	H3.0	SNM.1906..	
4040 S19	40	40	35	250	M5	721-1904	DLM 6	DLS 5	DSP 5	H4.0	H3.0	SNM.1906..	

DSDNN

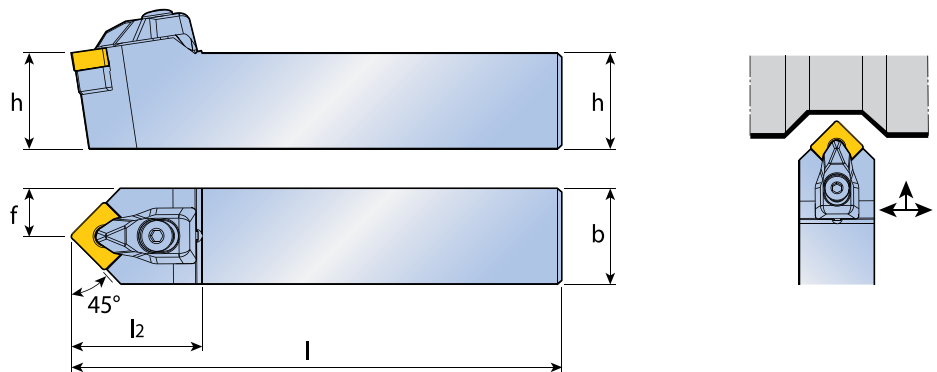

Державка Holder	Размеры Dimensions				Комплектация Spare parts								Режущая пластина Cutting insert
	h	b	f	l	Винт опорной пластины Shim screw	Пластина опорная Shim	Прихват Clamp	Винт прихвата Clamp screw	Пружина Spring	Ключ винта прихвата Key of clamp screw	Ключ винта опорной пластины Key of shim screw		
DSDNN 2020 K12	20	20	10	125	M3	721-1203	DLM 4	DLS 4	DSP 4	H3.0	H2.0	SNM.1204..	
2525 M12	25	25	12,5	150	M3	721-1203	DLM 4	DLS 4	DSP 4	H3.0	H2.0	SNM.1204..	
3232 P15	32	32	16	170	M5	721-1504	DLM 4	DLS 4	DSP 4	H3.0	H3.0	SNM.1506..	
3232 P19	32	32	16	170	M5	721-1904	DLM 6	DLS 5	DSP 5	H4.0	H3.0	SNM.1906..	
4040 S19	40	40	20	250	M5	721-1904	DLM 6	DLS 5	DSP 5	H4.0	H3.0	SNM.1906..	

DSKNR\l

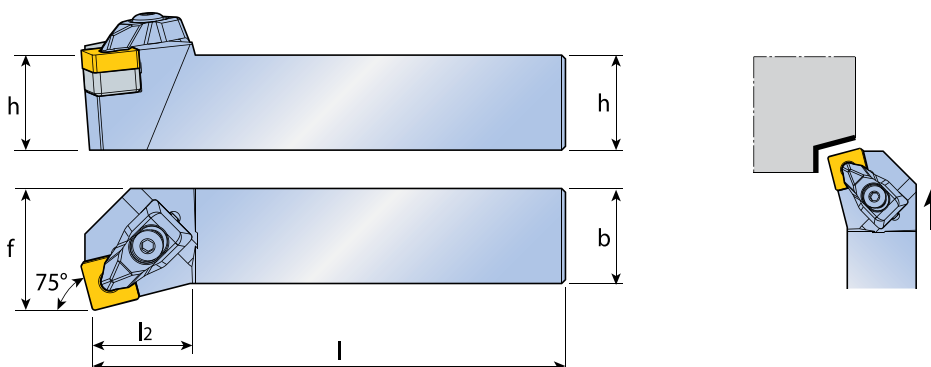

Державка Holder	Размеры Dimensions					Комплектация Spare parts							Режущая пластина Cutting insert
	h	b	f	l	Винт опорной пластины Shim screw	Пластина опорная Shim	Прихват Clamp	Винт прихвата Clamp screw	Пружина Spring	Ключ винта прихвата Key of clamp screw	Ключ винта опорной пластины Key of shim screw		
DSKNR\l 2020 K12	20	20	25	125	M3	721-1203	DLM 4	DLS 4	DSP 4	H3.0	H2.0	SNM.1204..	
2525 M12	25	25	32	150	M3	721-1203	DLM 4	DLS 4	DSP 4	H3.0	H2.0	SNM.1204..	
3225 P15	32	25	32	170	M3	721-1504	DLM 4	DLS 4	DSP 4	H3.0	H2.0	SNM.1506..	
3232 P19	32	32	40	170	M5	721-1904	DLM 6	DLS 5	DSP 5	H4.0	H3.0	SNM.1906..	
4040 S19	40	40	50	250	M5	721-1904	DLM 6	DLS 5	DSP 5	H4.0	H3.0	SNM.1906..	

DSSNR\l

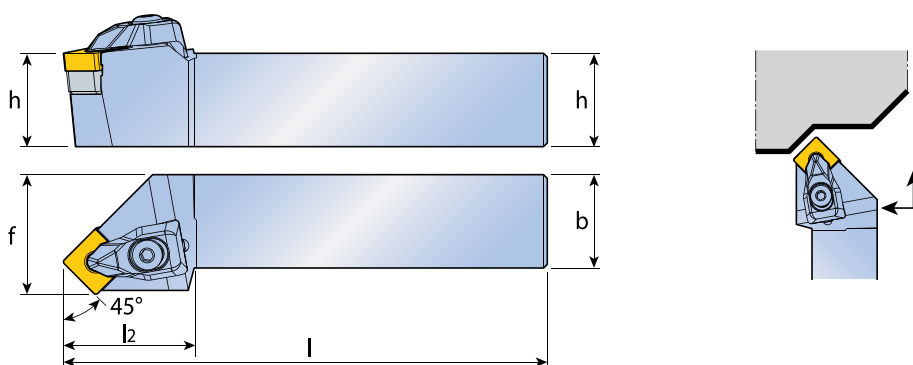

Державка Holder	Размеры Dimensions					Комплектация Spare parts							Режущая пластина Cutting insert
	h	b	f	l	Винт опорной пластины Shim screw	Пластина опорная Shim	Прихват Clamp	Винт прихвата Clamp screw	Пружина Spring	Ключ винта прихвата Key of clamp screw	Ключ винта опорной пластины Key of shim screw		
DSSNR\l 2020 K12	20	20	25	125	M3	721-1203	DLM 4	DLS 4	DSP 4	H3.0	H2.0	SNM.1204..	
2525 M12	25	25	32	150	M3	721-1203	DLM 4	DLS 4	DSP 4	H3.0	H2.0	SNM.1204..	
3225 P15	32	32	40	170	M5	721-1504	DLM 4	DLS 4	DSP 4	H3.0	H3.0	SNM.1506..	
3232 P19	32	32	40	170	M5	721-1904	DLM 6	DLS 5	DSP 5	H4.0	H3.0	SNM.1906..	
4040 R19	40	40	50	200	M5	721-1904	DLM 6	DLS 5	DSP 5	H4.0	H3.0	SNM.1906..	
4040 S19	40	40	50	250	M5	721-1904	DLM 6	DLS 5	DSP 5	H4.0	H3.0	SNM.1906..	

DTFNR/L

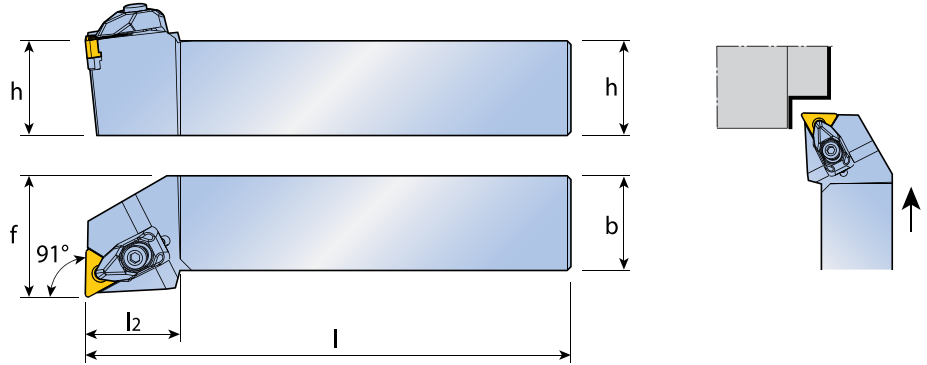

Державка Holder	Размеры Dimensions					Комплектация Spare parts							Режущая пластина Cutting insert
	h	b	f	l	Винт опорной пластины Shim screw	Пластина опорная Shim	Прихват Clamp	Винт прихвата Clamp screw	Пружина Spring	Ключ винта прихвата Key of clamp screw	Ключ винта опорной пластины Key of shim screw		
DTFNR/L 2020 K16	20	20	25	125	M4	701-1604	DLM 3	DLS 3	DSP 3	H2.5	H2.5	TNM.1604..	
2525 M16	25	25	32	150	M4	701-1604	DLM 3	DLS 3	DSP 3	H2.5	H2.5	TNM.1604..	
2525 M22	25	25	32	150	M5	701-2204	DLM 4	DLS 4	DSP 4	H3.0	H3.0	TNM.2204..	
3225 P22	32	25	32	170	M5	701-2204	DLM 4	DLS 4	DSP 4	H3.0	H3.0	TNM.2204..	

DTGNR/L

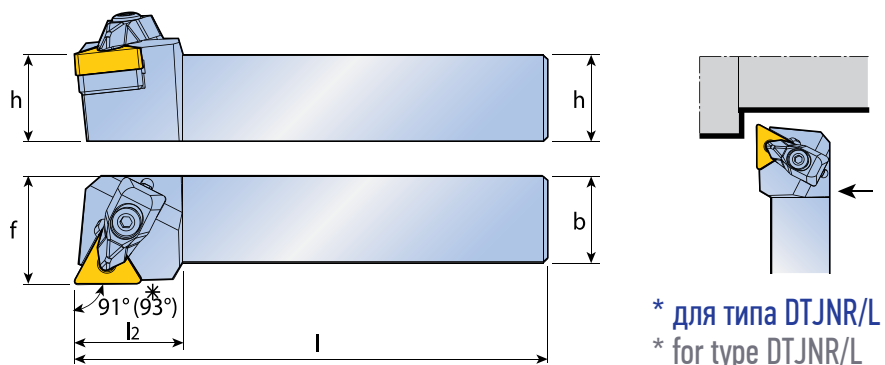

* для типа DTJNR/L
* for type DTJNR/L

Державка Holder	Размеры Dimintions					Комплектация Spare parts							Режущая пластина Cutting insert
	h	b	f	l	Винт опорной пластины Shim screw	Пластина опорная Shim	Прихват Clamp	Винт прихвата Clamp screw	Пружина Spring	Ключ винта прихвата Key of clamp screw	Ключ винта опорной пластины Key of shim screw		
DTGNR/L 2020 K16	20	20	25	125	M4	701-1604	DLM 3	DLS 3	DSP 3	H2.5	H2.5	TNM.1604..	
2525 M16	25	25	32	150	M4	701-1604	DLM 3	DLS 3	DSP 3	H2.5	H2.5	TNM.1604..	
2525 M22	25	25	32	150	M4	701-2204	DLM 4	DLS 4	DSP 4	H3.0	H3.0	TNM.2204..	
3225 P22	32	25	32	170	M4	701-2204	DLM 4	DLS 4	DSP 4	H3.0	H3.0	TNM.2204..	

DVJNR/L

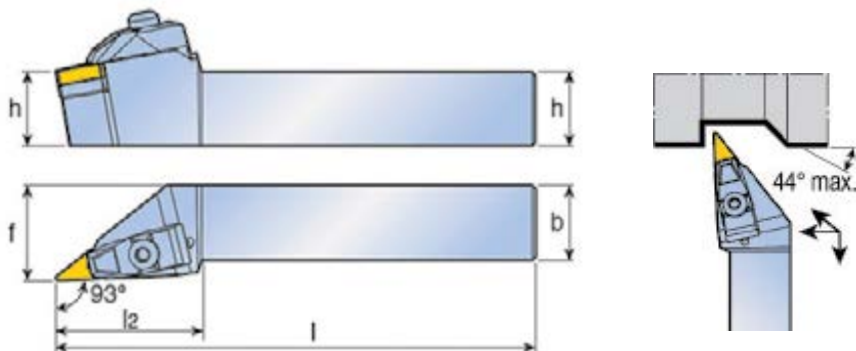
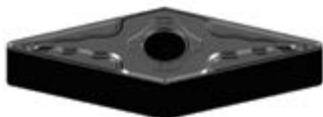

Державка Holder	Размеры Dimensions					Комплектация Spare parts							Режущая пластина Cutting insert
	h	b	f	l	Винт опорной пластины Shim screw	Пластина опорная Shim	Прихват Clamp	Винт прихвата Clamp screw	Пружина Spring	Ключ винта прихвата Key of clamp screw	Ключ винта опорной пластины Key of shim screw		
DVJNR/L	2525 M16	25	25	32	150	M3	DVN 160308	DLM 5	DLS 5	DSP 5	H4.0	H3.0	VNM. 1604..
	3225 P16	32	25	32	170	M3	DVN 160308	DLM 5	DLS 5	DSP 5	H4.0	H3.0	VNM. 1604..
	3232 P16	32	32	40	170	M3	DVN 160308	DLM 5	DLS 5	DSP 5	H4.0	H3.0	VNM. 1604..

DWLNR/L

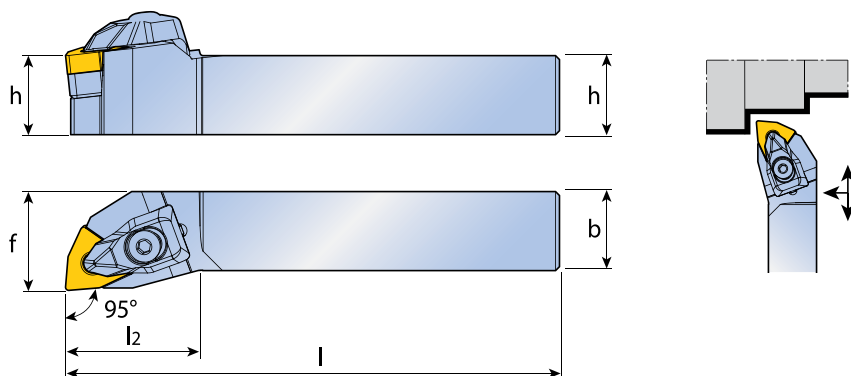

Державка Holder	Размеры Dimensions					Комплектация Spare parts							Режущая пластина Cutting insert
	h	b	f	l	Винт опорной пластины Shim screw	Пластина опорная Shim	Прихват Clamp	Винт прихвата Clamp screw	Пружина Spring	Ключ винта прихвата Key of clamp screw	Ключ винта опорной пластины Key of shim screw		
DWLNR/L	2020 K06	20	20	25	125	M3	711-0603	DLM 3	DLS 3	DSP 3	H2.5	H2.5	WNM. 0604..
	2020 K08	20	20	25	125	M5	711-0804	DLM 4	DLS 4	DSP 4	H3.0	H3.0	WNM. 0804..
	2525 M06	25	25	32	150	M3	711-0603	DLM 3	DLS 3	DSP 3	H2.5	H2.5	WNM. 0604..
	2525 M08	25	25	32	150	M5	711-0804	DLM 4	DLS 4	DSP 4	H3.0	H3.0	WNM. 0804..
	2525 M10	25	25	32	150	M5	711-1004	DLM 4	DLS 3	DSP 3	H2.5	H2.5	WNM. 0604..
	3225 P08	32	25	32	170	M5	711-0804	DLM 4	DLS 4	DSP 4	H3.0	H3.0	WNM. 0804..
	3232 P08	32	32	40	170	M5	711-0804	DLM 4	DLS 4	DSP 4	H3.0	H3.0	WNM. 0804..

S-DCLNR/L

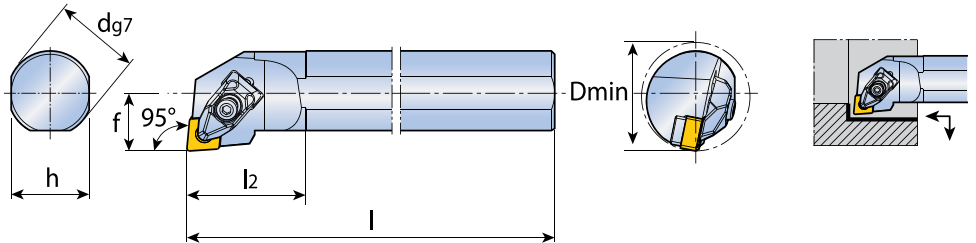
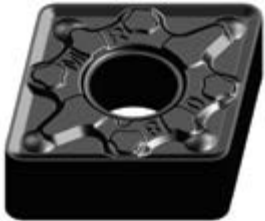

Державка Holder	Размеры Dimensions					Комплектация Spare parts							Режущая пластина Cutting insert
	d	h	l	f	Dmin	Винт опорной пластины Shim screw	Пластина опорная Shim	Прихват Clamp	Винт прихвата Clamp screw	Пружина Spring	Ключ винта прихвата Key of clamp screw	Ключ винта опорной пластины Key of shim screw	
S25T DCLNR/L 09	25	23	300	17	32	M3	731-0903	DLM 3	DLS 3	DSP 3	H2.5	H2.0	CNM. 0903..
S25T DCLNR/L 12	25	23	300	17	32	M3	731-1203	DLM 4	DLS 4	DSP 4	H3.0	H2.0	CNM. 1204..
S32U DCLNR/L 12	32	30	350	22	40	M3	731-1203	DLM 4	DLS 4	DSP 4	H3.0	H2.0	CNM. 1204..
S40T DCLNR/L 12	40	37	300	27	50	M3	731-1203	DLM 4	DLS 4	DSP 4	H3.0	H2.0	CNM. 1204..
S40V DCLNR/L 12	40	37	400	27	50	M3	731-1203	DLM 4	DLS 4	DSP 4	H3.0	H2.0	CNM. 1204..
S40V DCLNR/L 16	40	38	400	27	50	M5	731-1604	DLM 4	DLS 4	DSP 4	H3.0	H2.5	CNM. 1606..
S50U DCLNR/L 16	50	47	350	35	62	M5	731-1604	DLM 4	DLS 4	DSP 4	H3.0	H2.5	CNM. 1606..
S50V DCLNR/L 19	50	47	400	35	62	M5	731-1904	DLM 6	DLS 5	DSP 5	H4.0	H3.0	CNM. 1906..

S-DSKNR/L

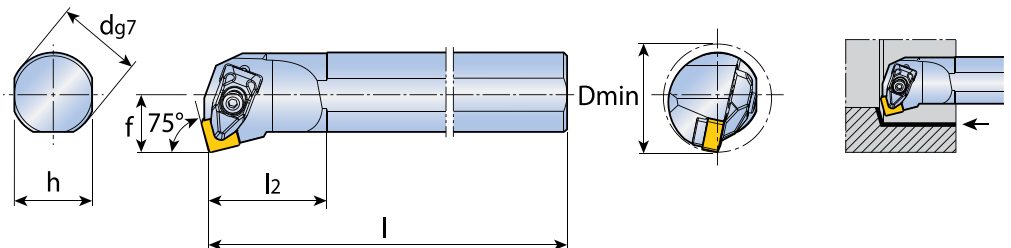

Державка Holder	Размеры Dimensions					Комплектация Spare parts							Режущая пластина Cutting insert
	d	h	l	f	Dmin	Винт опорной пластины Shim screw	Пластина опорная Shim	Прихват Clamp	Винт прихвата Clamp screw	Пружина Spring	Ключ винта прихвата Key of clamp screw	Ключ винта опорной пластины Key of shim screw	
S25T DSKNR/L 12	25	23	300	17	32	M3	721-1203	DLM 4	DLS 4	DSP 4	H3.0	H2.0	SNM. 1204..
S32U DSKNR/L 12	32	30	350	22	40	M3	721-1203	DLM 4	DLS 4	DSP 4	H3.0	H2.0	SNM. 1204..
S40V DSKNR/L 16	40	37	400	27	50	M5	721-1504	DLM 4	DLS 4	DSP 4	H3.0	H3.0	SNM. 1606..
S50V DSKNR/L 19	50	47	400	35	62	M5	721-1904	DLM 6	DLS 5	DSP 5	H4.0	H3.0	SNM. 1906..

S-DDUNR/L

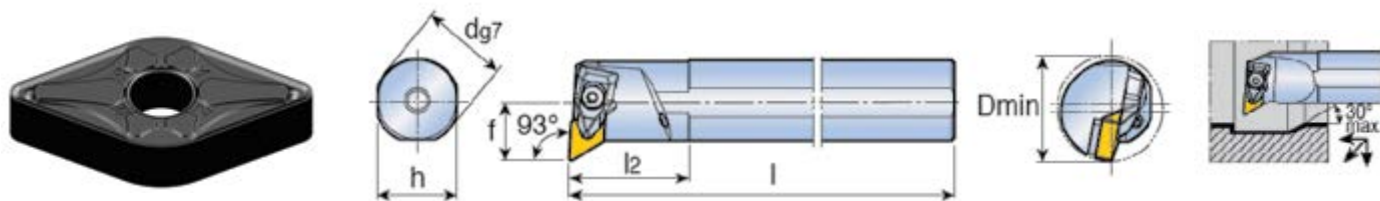

Державка Holder	Размеры Dimensions					Комплектация Spare parts							Режущая пластина Cutting insert
	d	h	l	f	Dmin	Винт опорной пластины Shim screw	Пластина опорная Shim	Прихват Clamp	Винт прихвата Clamp screw	Пружина Spring	Ключ винта прихвата Key of clamp screw	Ключ винта опорной пластины Key of shim screw	
S32T DDUNR/L 15	32	30	300	22	40	SO 40100	781-1503 781-1504	DLM 4	DLS 4	DSP 4	H3.0	H2.5	DNM. 1504../1506
S40U DDUNR/L 15	40	38	350	27	50	SO 40100	781-1503 781-1504	DLM 4	DLS 4	DSP 4	H3.0	H2.5	DNM. 1504../1506
S50U DDUNR/L 15	50	47	350	35	62	SO 40100	781-1503 781-1504	DLM 4	DLS 4	DSP 4	H3.0	H2.5	DNM. 1504../1506

S-DWLNR/L

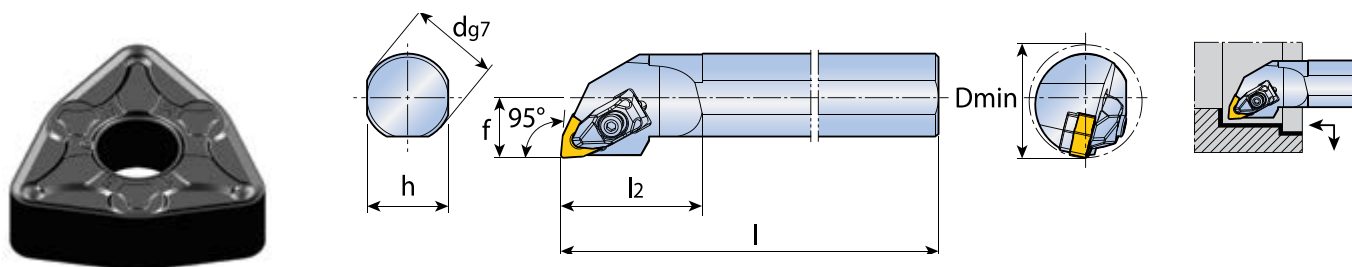

Державка Holder	Размеры Dimensions					Комплектация Spare parts							Режущая пластина Cutting insert
	d	h	l	f	Dmin	Винт опорной пластины Shim screw	Пластина опорная Shim	Прихват Clamp	Винт прихвата Clamp screw	Пружина Spring	Ключ винта прихвата Key of clamp screw	Ключ винта опорной пластины Key of shim screw	
S25T DWLNR/L 08	25	23	300	17	32	M5	711-0804	DLM 4	DLS 4	DSP 4	H3.0	H3.0	WNM. 0804..
S32U DWLNR/L 08	32	30	350	22	40	M5	711-0804	DLM 4	DLS 4	DSP 4	H3.0	H3.0	WNM. 0804..
S40V DWLNR/L 08	40	37	400	27	50	M5	711-0804	DLM 4	DLS 4	DSP 4	H3.0	H3.0	WNM. 0804..

MTJNR/L

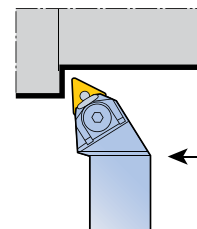
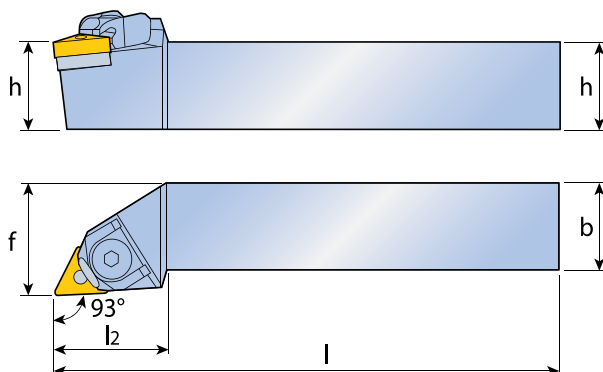

Державка Holder	Размеры Dimensions				Комплектация Spare parts						Режущая пластина Cutting insert
	h	b	f	l	Прихват Clamp	Пластина опорная Shim	Штифт Pin	Винт прижима Screw clamp	Пружина Spring	Ключ прихвата Clamp key	
MTJNR/L 2020 K16	20	20	25	125	WT 16	701-1603	MC 3	DLS 4	DSP 4	H3.0	TNM. 1604..
2525 M16	25	25	32	150	WT 16	701-1603	MC 3	DLS 4	DSP 4	H3.0	TNM. 1604..
2525 M22	25	25	32	150	WC 43	701-2204	MC 5	DLS 5	DSP 5	H4.0	TNM. 2204..
3225 P22	32	25	32	170	WC 43	701-2204	MC 5	DLS 5	DSP 5	H4.0	TNM. 2204..
3232 P22	32	32	40	170	WC 43	701-2204	MC 5	DLS 5	DSP 5	H4.0	TNM. 2204..

MVJNR/L

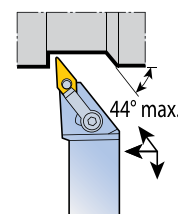
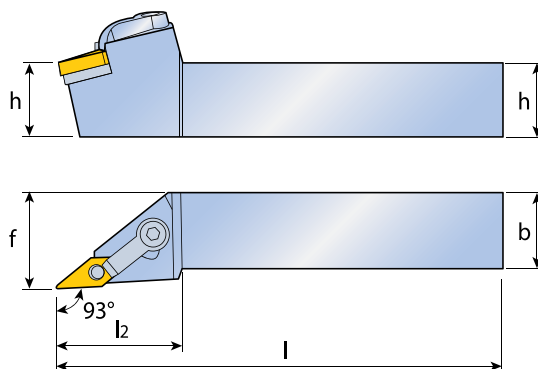
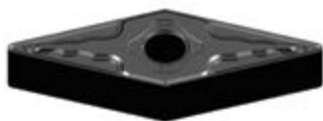

Державка Holder	Размеры Dimensions				Комплектация Spare parts						Режущая пластина Cutting insert
	h	b	f	l	Прихват Clamp	Пластина опорная Shim	Штифт Pin	Винт прижима Screw clamp	Пружина Spring	Ключ прихвата Clamp key	
MVJNR/L 2020 K16	20	20	25	125	IR 186	MVN 160304	MC 3	DLS 5	DSP 5	H4.0	VNM. 1604..
2525 M16	25	25	32	150	IR 186	MVN 160304	MC 3	DLS 5	DSP 5	H4.0	VNM. 1604..
3225 P16	32	25	32	170	IR 186	MVN 160304	MC 3	DLS 5	DSP 5	H4.0	VNM. 1604..
3232 P16	32	32	40	170	IR 186	MVN 160304	MC 3	DLS 5	DSP 5	H4.0	VNM. 1604..

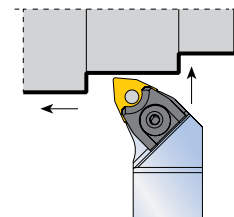
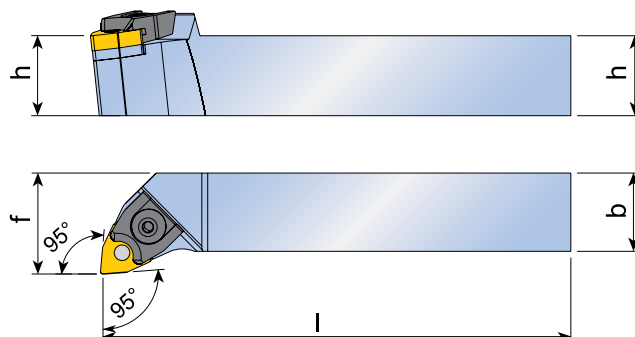
MWLNRL

Державка Holder	Размеры Dimensions					Комплектация Spare parts						Режущая пластина Cutting insert
	h	b	f	l	Прихват Clamp	Пластина опорная Shim	Штифт Pin	Винт прижима Screw clamp	Пружина Spring	Ключ прихвата Clamp key		
MWLNRL 2020 K06	20	20	25	125	MW 06	711-0603	MC 4	DLS 3	DSP 3	H2.5	WNM. 0604..	
2020 K08	20	20	25	125	MW051	711-0804	MC 5	DLS 5	DSP 5	H4.0	WNM. 0804..	
2525 M06	25	25	32	150	MW 06	711-0603	MC 4	DLS 3	DSP 3	H2.5	WNM. 0604..	
2525 M08	25	25	32	150	MW051	711-0804	MC 5	DLS 5	DSP 5	H4.0	WNM. 0804..	
3225 P08	32	25	32	170	MW051	711-0804	MC 5	DLS 5	DSP 5	H4.0	WNM. 0804..	
3232 P08	32	32	40	170	MW051	711-0804	MC 5	DLS 5	DSP 5	H4.0	WNM. 0804..	
3232 R12	32	32	40	170	MW 12	711-1206	MC 6	DLS 5	DSP 5	H4.0	WNM. 1206..	
4040 R08	40	40	50	200	MW051	711-0804	MC 5	DLS 5	DSP 5	H4.0	WNM. 0804..	
4040 R12	40	40	50	200	MW 12	711-1206	MC 6	DLS 5	DSP 5	H4.0	WNM. 1206..	

S-MTFNR/L

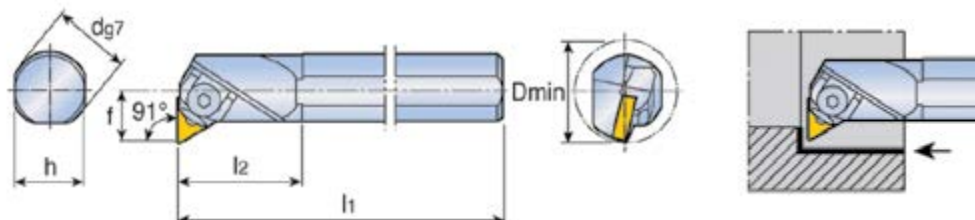

Державка Holder	Размеры Dimensions					Комплектация Spare parts						Режущая пластина Cutting insert
	d	h	l	f	Dmin	Прихват Clamp	Пластина опорная Shim	Штифт Pin	Винт прижима Screw clamp	Пружина Spring	Ключ прихвата Clamp key	
S25T MTFNR/L 16	25	23	300	17	32	WT 16	701-1603	MC 3	DLS 4	DSP4	H3.0	TNM. 1604..
S32U MTFNR/L 16	32	30	350	22	40	WT 16	701-1603	MC 3	DLS 4	DSP4	H3.0	TNM. 1604..
S40V MTFNR/L 16	40	37	400	27	50	WT 16	701-1603	MC 3	DLS 4	DSP4	H3.0	TNM. 1604..

S-MWLNR/L

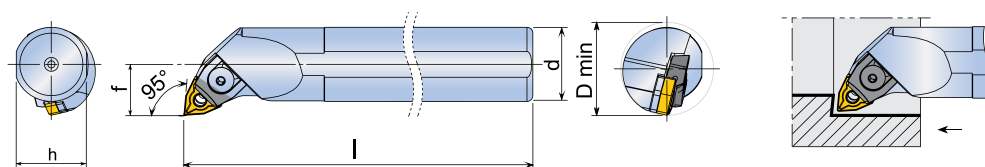

Державка Holder	Размеры Dimensions					Комплектация Spare parts						Режущая пластина Cutting insert
	d	h	l	f	Dmin	Прихват Clamp	Пластина опорная Shim	Штифт Pin	Винт прижима Screw clamp	Пружина Spring	Ключ прихвата Clamp key	
S20S MWLNR/L 06	20	18	250	13	25	MW 06	711-0603	MC 4	DLS 3	DSP3	H3.0	WNM. 0604..
S25T MWLNR/L 06	25	23	300	17	32	MW 06	711-0603	MC 4	DLS 3	DSP3	H3.0	WNM. 0604..
S25T MWLNR/L 08	25	23	300	17	32	MW051	711-0804	MC 5	DLS 5	DSP3	H4.0	WNM. 0804..
S32U MWLNR/L 06	32	30	350	22	40	MW 06	711-0603	MC 4	DLS 3	DSP3	H3.0	WNM. 0604..
S32U MWLNR/L 08	32	30	350	22	40	MW051	711-0804	MC 5	DLS 5	DSP5	H4.0	WNM. 0804..
S40V MWLNR/L 08	40	37	400	27	50	MW051	711-0804	MC 5	DLS 5	DSP5	H4.0	WNM. 0804..
S50W MWLNR/L 08	50	48,5	450	35	63	MW051	711-0804	MC 5	DLS 5	DSP5	H4.0	WNM. 0804..

PCBNR/L

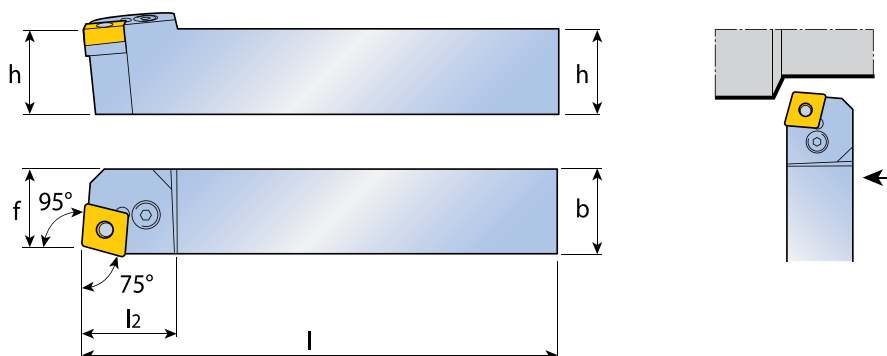

Державка Holder	Размеры Dimensions				Комплектация Spare parts					Режущая пластина Cutting insert	
	h	b	f	l	Винт рычага Lever screw	Пластина опорная Shim	Рычаг Lever	Втулка Shim pin	Ключ Key		
PCBNRL	2020 K12	20	20	17	125	US 42	CNU 120312	PU 02	NT 05	H4.0	CNM. 1204..
	2525 M12	25	25	22	150	US 35	CNU 120312	PU 02	NT 05	H4.0	CNM. 1204..
	3225 P12	32	25	22	170	US 35	CNU 120312	PU 02	NT 05	H4.0	CNM. 1204..
	3232 P16	32	32	27	170	US 36	CNU 150312	PU 04	NT 07	H4.0	CNM. 1606..
	3232 P19	32	32	27	170	US 38	CNU 190416	PU 05	NT 06	H5.0	CNM. 1906..
	4040 R19	40	40	35	200	US 38	CNU 190416	PU 05	NT 06	H5.0	CNM. 1906..
	4040 S25	40	40	35	250	US 39	CNU 250620	PU 06	NT 08	H5.0	CNM. 2507..
	4040 S2509	40	40	35	250	US 39	CNU 250620	PU 06	NT 08	H5.0	CNM. 2509..
	5050 T25	50	50	43	300	US 39	CNU 250620	PU 06	NT 08	H5.0	CNM. 2507..
	5050 T2509	50	50	43	300	US 39	CNU 250620	PU 06	NT 08	H5.0	CNM. 2509..

PCKNR/L

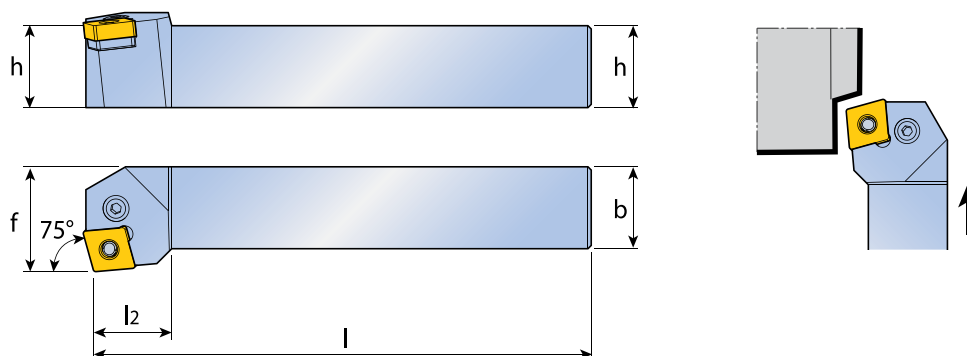

Державка Holder	Размеры Dimensions				Комплектация Spare parts					Режущая пластина Cutting insert	
	h	b	f	l	Винт рычага Lever screw	Пластина опорная Shim	Рычаг Lever	Втулка Shim pin	Ключ Key		
PCKNRL	2020 K12	20	20	25	125	US 42	CNU 120312	PU 02	NT 05	H4.0	CNM. 1204..
	2525 M12	25	25	32	150	US 35	CNU 120312	PU 02	NT 05	H4.0	CNM. 1204..
	3225 P12	32	25	40	170	US 35	CNU 120312	PU 02	NT 05	H4.0	CNM. 1204..
	3232 P16	32	32	40	170	US 36	CNU 150312	PU 04	NT 07	H4.0	CNM. 1606..
	3232 P19	32	32	40	170	US 38	CNU 190416	PU 05	NT 06	H5.0	CNM. 1906..
	4040 S19	40	40	50	250	US 38	CNU 190416	PU 05	NT 06	H5.0	CNM. 1906..

PCLNR/L

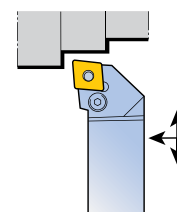
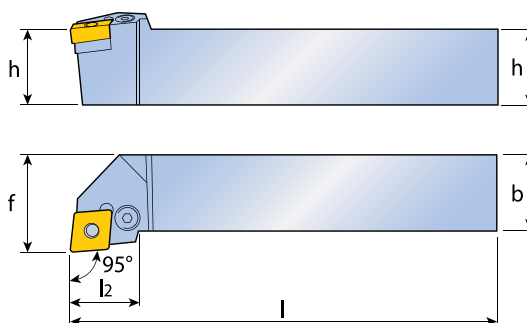
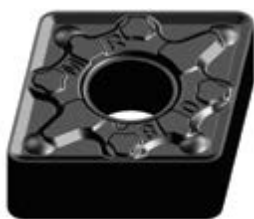

Державка Holder	Размеры Dimensions				Комплектация Spare parts					Режущая пластина Cutting insert
	h	b	f	l	Винт рычага Lever screw	Пластина опорная Shim	Рычаг Lever	Втулка Shim pin	Ключ Key	
PCLNR/L 1616 H09	16	16	20	100	US 34	CNU 090312	PU 01	NT 04	H2.0	CNM. 0904..
1616 H12	16	16	20	100	US 42	CNU 120312	PU 02	NT 05	H4.0	CNM. 1204..
2020 K09	20	20	25	125	US 34	CNU 090312	PU 01	NT 04	H2.0	CNM. 0904..
2020 K12	20	20	25	125	US 42	CNU 120312	PU 02	NT 05	H4.0	CNM. 1204..
2525 M12	25	25	32	150	US 35	CNU 120312	PU 02	NT 05	H4.0	CNM. 1204..
2525 M16	25	25	32	150	US 36	CNU 150312	PU 04	NT 07	H4.0	CNM. 1606..
2525 M19	25	25	32	150	US 38	CNU 190416	PU 05	NT 06	H5.0	CNM. 1906..
3225 P12	32	25	32	170	US 35	CNU 120312	PU 02	NT 05	H4.0	CNM. 1204..
3225 P16	32	25	32	170	US 36	CNU 150312	PU 04	NT 07	H4.0	CNM. 1606..
3232 P16	32	32	40	170	US 36	CNU 150312	PU 04	NT 07	H4.0	CNM. 1606..
3232 P19	32	32	40	170	US 38	CNU 190416	PU 05	NT 06	H5.0	CNM. 1906..
4040 R19	40	40	50	200	US 38	CNU 190416	PU 05	NT 06	H5.0	CNM. 1906..
4040 S25	40	404	50	250	US 39	CNU 250620	PU 06	NT 08	H5.0	CNM. 2507..
4040 S2509	40	404	50	250	US 39	CNU 250620	PU 06	NT 08	H5.0	CNM. 2509..
5050 T25	50	50	60	300	US 39	CNU 250620	PU 06	NT 08	H5.0	CNM. 2507..
5050 T2509	50	50	60	300	US 39	CNU 250620	PU 06	NT 08	H5.0	CNM. 2509..

PDJNR/L

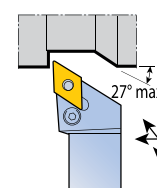
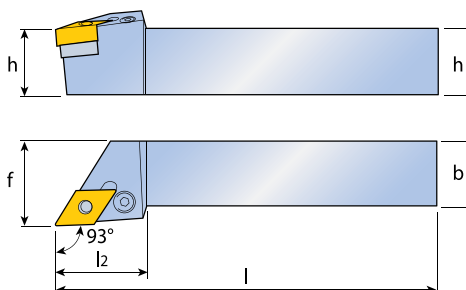

Державка Holder	Размеры Dimensions				Комплектация Spare parts					Режущая пластина Cutting insert
	h	b	f	l	Винт рычага Lever screw	Пластина опорная Shim	Рычаг Lever	Втулка Shim pin	Ключ Key	
PDJNR/L 1616 H11	16	16	20	100	PS 0616	PDN 110308	PU 3512	NT 5153	H2.5	DNM. 1104..
2020 K11	20	20	25	125	PS 0616	PDN 110308	PU 3512	NT 5153	H2.5	DNM. 1104..
2525 M11	25	25	32	150	PS 0616	PDN 110308	PU 3512	NT 5153	H2.5	DNM. 1104..
3225 P11	32	25	32	170	PS 0616	PDN 110308	PU 3512	NT 5153	H2.5	DNM. 1104..
2020 K15	20	20	25	125	US 40	DNU 150308	PU 03	NT 05	H4.0	DNM. 1506..
2525 M15	25	25	32	150	US 36	DNU 150308	PU 03	NT 05	H4.0	DNM. 1506..
3225 P15	32	25	32	170	US 36	DNU 150308	PU 03	NT 05	H4.0	DNM. 1506..
3232 P15	32	32	40	170	US 36	DNU 150308	PU 03	NT 05	H4.0	DNM. 1506..
4040 P15	40	40	50	170	US 36	DNU 150308	PU 03	NT 05	H4.0	DNM. 1506..

PDNNR/L

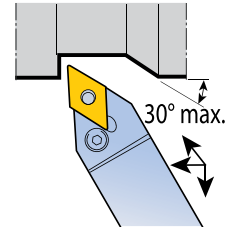
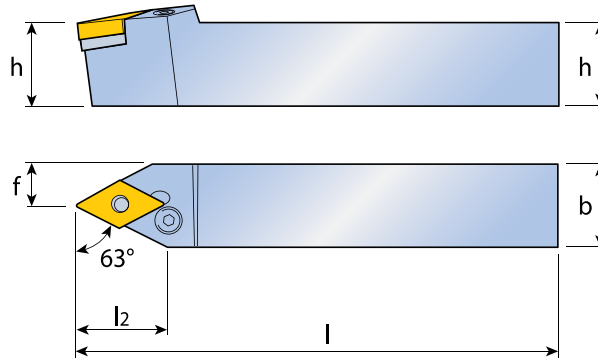

Державка Holder	Размеры Dimensions				Комплектация Spare parts					Режущая пластина Cutting insert
	h	b	f	l	Винт рычага Lever screw	Пластина опорная Shim	Рычаг Lever	Втулка Shim pin	Ключ Key	
PDNNR/L 2020 K11	20	20	10	125	PS 0616	PDN110308	PU 3512	NT 5153	H2.5	DNM.1104..
2525 M11	25	25	12,5	150	PS 0616	PDN110308	PU 3512	NT 5153	H2.5	DNM.1104..
2525 M15	25	25	12,5	150	US 36	DNU 150308	PU 03	NT 05	H4.0	DNM.1506..
3225 H15	32	25	12,5	100	US 36	DNU 150308	PU 03	NT 05	H4.0	DNM.1506..
3225 P15	32	25	12,5	170	US 36	DNU 150308	PU 03	NT 05	H4.0	DNM.1506..

PRDCN

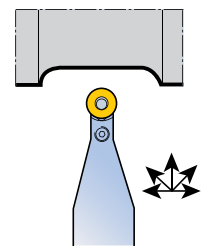
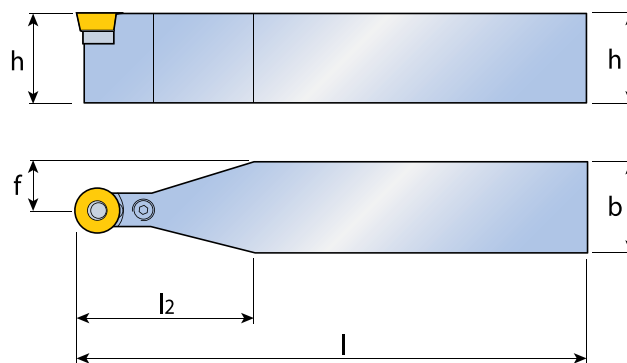

Державка Holder	Размеры Dimensions				Комплектация Spare parts					Режущая пластина Cutting insert
	h	b	f	l	Винт рычага Lever screw	Пластина опорная Shim	Рычаг Lever	Втулка Shim pin	Ключ Key	
PRDCN 3225 P16	32	25	12,5	170	US 36	RCU 160400	PU 07	NT 05	H4.0	RCTX 1606..
3232 P20	32	32	16	170	US 36	RCU 200400	PU 09	NT 07	H4.0	RCTX 2006..
4040 S20	40	40	20	250	US 36	RCU 200400	PU 09	NT 07	H4.0	RCTX 2006..
4040 S25	40	40	20	250	US 38	RCU 250600	PU 08	NT 06	H5.0	RCTX 2507..
5050 T32	50	50	25	300	US 47	RCU 320600	PU 10	NT 08	H5.0	RCTX 3209..

PRGCR/L

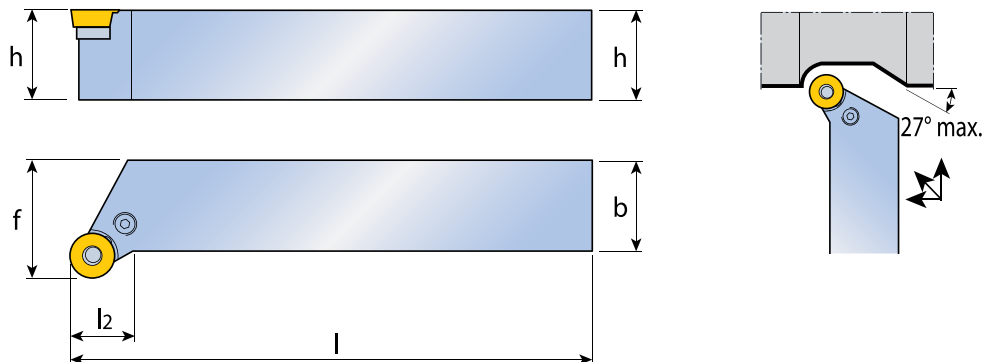

Державка Holder	Размеры Dimensions					Комплектация Spare parts					Режущая пластина Cutting insert
	h	b	f	l	Винт рычага Lever screw	Пластина опорная Shim	Рычаг Lever	Втулка Shim pin	Ключ Key		
PRSCRIL 3225 P16	32	25	32	170	US 36	RCU 160400	PU 07	NT 05	H4.0	RCMX 1606..	
3232 P20	32	32	40	170	US 36	RCU 200400	PU 09	NT 07	H4.0	RCMX 2006..	
4040 R16	40	40	50	200	US 36	RCU 160400	PU 07	NT 05	H4.0	RCMX 1606..	
4040 S25	40	40	50	250	US 38	RCU 250600	PU 08	NT 06	H5.0	RCMX 2507..	

PRSNR/L

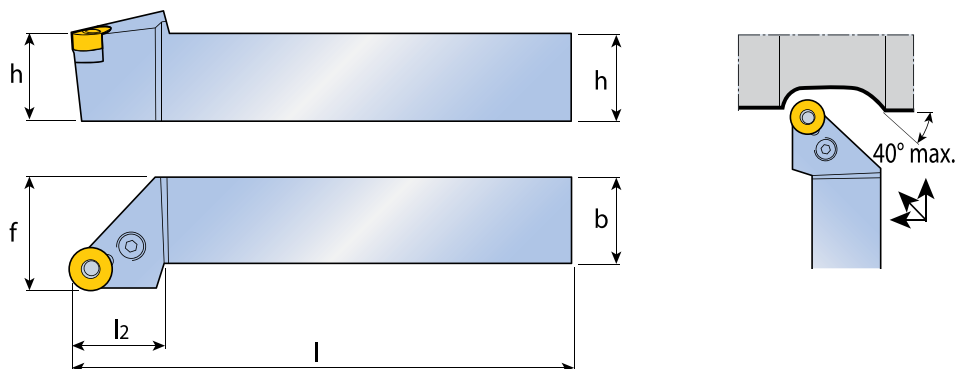

Державка Holder	Размеры Dimensions					Комплектация Spare parts					Режущая пластина Cutting insert
	h	b	f	l	Винт рычага Lever screw	Пластина опорная Shim	Рычаг Lever	Втулка Shim pin	Ключ Key		
PRSNRIL 2525 M12	25	25	32	150	US 35	RNU 120300	PU 02	NT 05	H4.0	RNM.120400	
3232 P15	32	32	40	170	US 36	RNU 150300	PU 04	NT 07	H4.0	RNM.150600	
4040 R19	40	40	50	200	US 38	RNU 190400	PU 05	NT 06	H5.0	RNM.190600	

PSBNRL

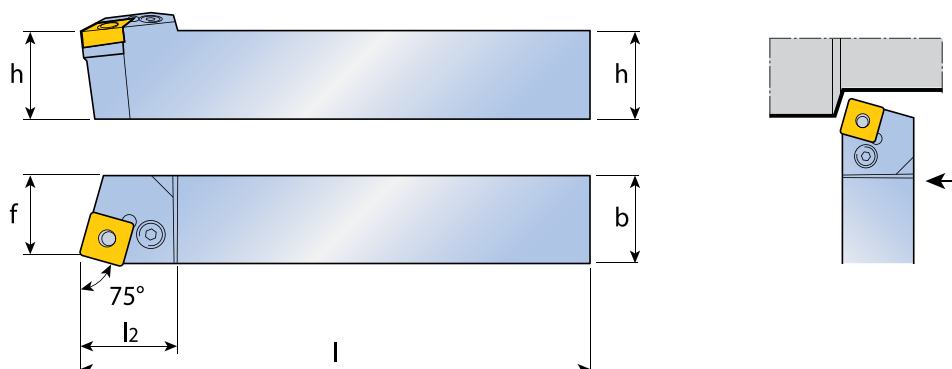

Державка Holder	Размеры Dimensions				Комплектация Spare parts					Режущая пластина Cutting insert
	h	b	f	l	Винт рычага Lever screw	Пластина опорная Shim	Рычаг Lever	Втулка Shim pin	Ключ Key	
PSBNRL 2020 K12	20	20	17	125	US 42	SNU 120312	PU 02	NT 05	H4.0	SNM. 1204..
2525 M12	25	25	22	150	US 35	SNU 120312	PU 02	NT 05	H4.0	SNM. 1204..
2525 M15	32	25	22	170	US 36	SNU 150312	PU 04	NT 07	H4.0	SNM. 1506..
3225 P15	32	25	22	170	US 36	SNU 150312	PU 04	NT 07	H4.0	SNM. 1506..
3232 P19	32	32	27	170	US 38	SNU 190416	PU 05	NT 06	H5.0	SNM. 1906..
4040 R19	40	40	35	200	US 38	SNU 190416	PU 05	NT 06	H5.0	SNM. 1906..
4040 S25	40	40	35	250	US 39	SNU 250624	PU 06	NT 08	H5.0	SNM. 2507..
4040 S2509	40	40	35	250	US 39	SNU 250624	PU 06	NT 08	H5.0	SNM. 2509..
5050 T25	50	50	43	300	US 39	SNU 250624	PU 06	NT 08	H5.0	SNM. 2507..
5050 T2509	50	50	43	300	US 39	SNU 250624	PU 06	NT 08	H5.0	SNM. 2509..

PSDNN

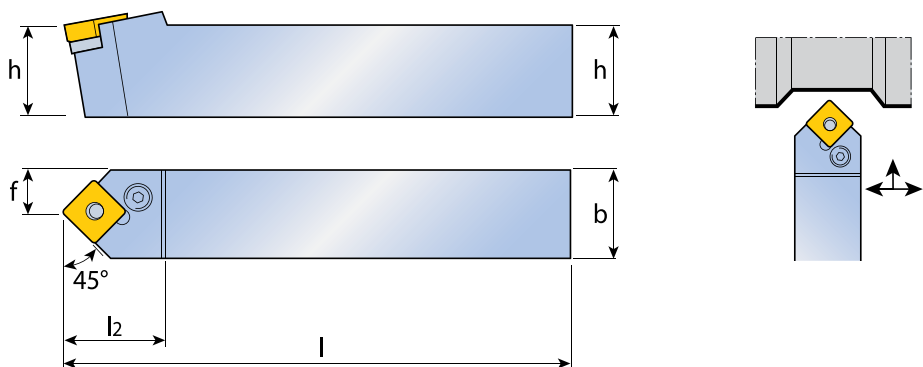

Державка Holder	Размеры Dimensions				Комплектация Spare parts					Режущая пластина Cutting insert
	h	b	f	l	Винт рычага Lever screw	Пластина опорная Shim	Рычаг Lever	Втулка Shim pin	Ключ Key	
PSDNN 2020 K12	20	20	10	125	US 42	SNU 120312	PU 02	NT 05	H4.0	SNM. 1204..
2525 M12	25	25	12,5	150	US 35	SNU 120312	PU 02	NT 05	H4.0	SNM. 1204..
3232 P15	32	32	16	170	US 36	SNU 150312	PU 04	NT 07	H4.0	SNM. 1506..
3232 P19	32	32	16	170	US 38	SNU 190416	PU 05	NT 06	H5.0	SNM. 1906..
4040 S19	40	40	20	250	US 38	SNU 190416	PU 05	NT 06	H5.0	SNM. 1906..
4040 S25	40	40	20	250	US 39	SNU 250624	PU 06	NT 08	H5.0	SNM. 2507..
5050 T25	50	50	25	300	US 39	SNU 250624	PU 06	NT 08	H5.0	SNM. 2507..

PSKNR/L

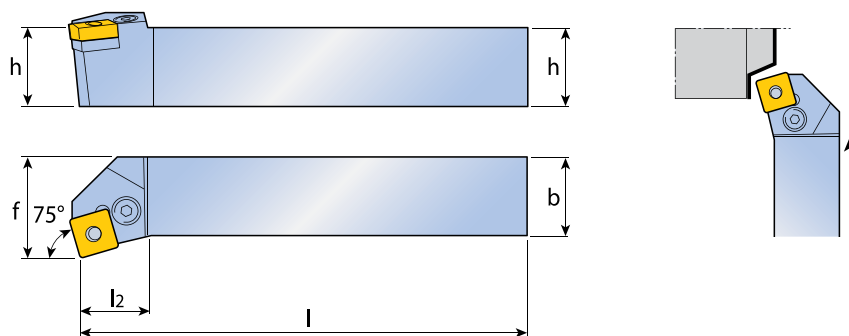

Державка Holder	Размеры Dimensions				Комплектация Spare parts					Режущая пластина Cutting insert
	h	b	f	l	Винт рычага Lever screw	Пластина опорная Shim	Рычаг Lever	Втулка Shim pin	Ключ Key	
PSKNR/L 2020 K12	20	20	25	125	US 42	SNU 120312	PU 02	NT 05	H4.0	SNM. 1204..
2525 M12	25	25	32	150	US 35	SNU 120312	PU 02	NT 05	H4.0	SNM. 1204..
2525 M15	25	25	32	150	US 36	SNU 150312	PU 04	NT 07	H4.0	SNM. 1506..
3225 P15	32	25	32	170	US 36	SNU 150312	PU 04	NT 07	H4.0	SNM. 1506..
3232 P19	32	32	40	170	US 38	SNU 190416	PU 05	NT 06	H5.0	SNM. 1906..
4040 R19	40	40	50	200	US 38	SNU 190416	PU 05	NT 06	H5.0	SNM. 1906..
4040 S25	40	40	50	250	US 39	SNU 250624	PU 06	NT 08	H5.0	SNM. 2507..
5050 T25	50	50	60	300	US 39	SNU 250624	PU 06	NT 08	H5.0	SNM. 2507..

PSSNR/L

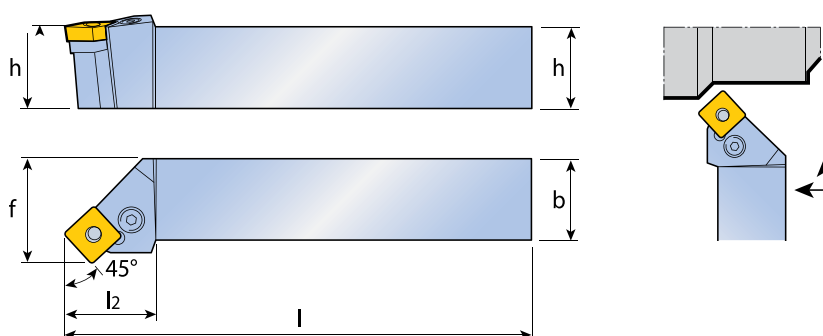

Державка Holder	Размеры Dimensions				Комплектация Spare parts					Режущая пластина Cutting insert
	h	b	f	l	Винт рычага Lever screw	Пластина опорная Shim	Рычаг Lever	Втулка Shim pin	Ключ Key	
PSSNR/L 2020 K12	20	20	25	125	US 42	SNU 120312	PU 02	NT 05	H4.0	SNM. 1204..
2525 M12	25	25	32	150	US 35	SNU 120312	PU 02	NT 05	H4.0	SNM. 1204..
2525 M15	25	25	32	150	US 36	SNU 150312	PU 04	NT 07	H5.0	SNM. 1506..
3225 P15	32	25	32	170	US 36	SNU 150312	PU 04	NT 07	H5.0	SNM. 1506..
3232 P15	32	32	40	170	US 36	SNU 150312	PU 04	NT 07	H5.0	SNM. 1506..
3232 P19	32	32	40	170	US 38	SNU 190416	PU 05	NT 06	H5.0	SNM. 1906..
4040 R19	40	40	50	200	US 38	SNU 190416	PU 05	NT 06	H5.0	SNM. 1906..
4040 S25	40	40	50	250	US 39	SNU 250624	PU 06	NT 08	H5.0	SNM. 2507..
5050 T25	50	50	60	300	US 39	SNU 250624	PU 06	NT 08	H5.0	SNM. 2507..

PTFNR/L

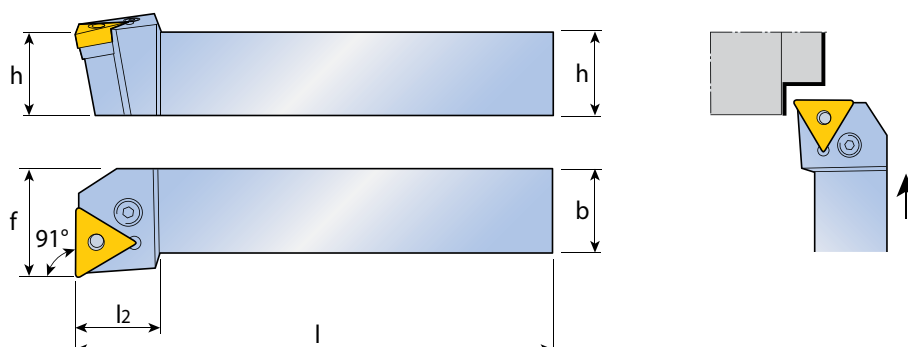

Державка Holder	Размеры Dimensions				Комплектация Spare parts					Режущая пластина Cutting insert
	h	b	f	l	Винт рычага Lever screw	Пластина опорная Shim	Рычаг Lever	Втулка Shim pin	Ключ Key	
PTFNRL 1616 H16	16	16	20	100	US 46	LST31.8	PU 01	NT 04	H3.0	TNM.1604..
2020 K16	20	20	25	125	US 34	LST31.8	PU 01	NT 04	H3.0	TNM.1604..
2525 M16	25	25	32	150	US 34	LST31.8	PU 01	NT 04	H3.0	TNM.1604..
2525 M22	25	25	32	150	US 35	TNU 220312	PU 02	NT 05	H4.0	TNM.2204..
3225 P22	32	25	32	170	US 35	TNU 220312	PU 02	NT 05	H4.0	TNM.2204..
4040 R27	40	40	50	200	US 36	TNU 270416	PU 04	NT 07	H4.0	TNM.2706..

PTGNR/L

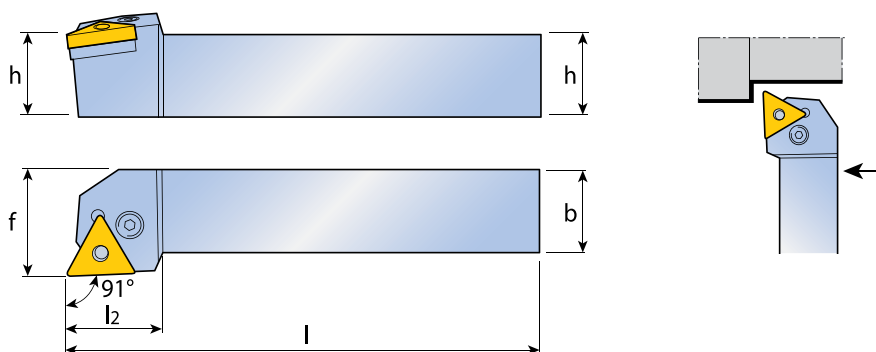

Державка Holder	Размеры Dimensions				Комплектация Spare parts					Режущая пластина Cutting insert
	h	b	f	l	Винт рычага Lever screw	Пластина опорная Shim	Рычаг Lever	Втулка Shim pin	Ключ Key	
PTGNRL 1616 H16	16	16	20	100	US 46	TNU 160308	PU 01	NT 04	H3.0	TNM.1604..
2020 K16	20	20	25	125	US 34	TNU 160308	PU 01	NT 04	H3.0	TNM.1604..
2525 M16	25	25	32	150	US 34	TNU 160308	PU 01	NT 04	H3.0	TNM.1604..
2525 M22	25	25	32	150	US 35	TNU 220312	PU 02	NT 05	H4.0	TNM.2204..
3225 P22	32	25	32	170	US 35	TNU 220312	PU 02	NT 05	H4.0	TNM.2204..
3232 P22	32	32	40	170	US 35	TNU 220312	PU 02	NT 05	H4.0	TNM.2204..
4040 R27	40	40	50	250	US 36	TNU 270416	PU 04	NT 07	H4.0	TNM.2706..
5050 S27	50	50	60	250	US 36	TNU 270416	PU 04	NT 07	H4.0	TNM.2706..

PTTNR/L

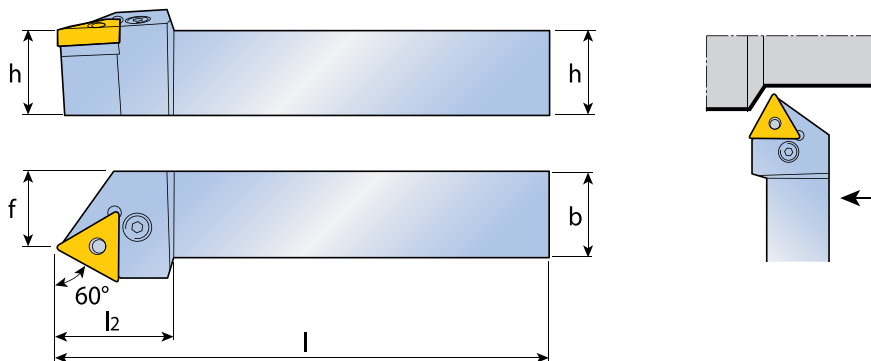

Державка Holder	Размеры Dimensions				Комплектация Spare parts					Режущая пластина Cutting insert
	h	b	f	l	Винт рычага Lever screw	Пластина опорная Shim	Рычаг Lever	Втулка Shim pin	Ключ Key	
PTTNR/L 2020 K16	20	20	17	125	US 34	LST31.8	PU 01	NT 04	H3.0	TNM.1604..
2525 M16	25	25	22	150	US 34	LST31.8	PU 01	NT 04	H3.0	TNM.1604..
3225 P16	32	25	22	170	US 34	LST31.8	PU 01	NT 04	H3.0	TNM.1604..
2525 M22	25	25	22	150	US 35	TNU 220312	PU 02	NT 05	H4.0	TNM.2204..
3225 P22	32	25	22	170	US 35	TNU 220312	PU 02	NT 05	H4.0	TNM.2204..

PWLNR/L

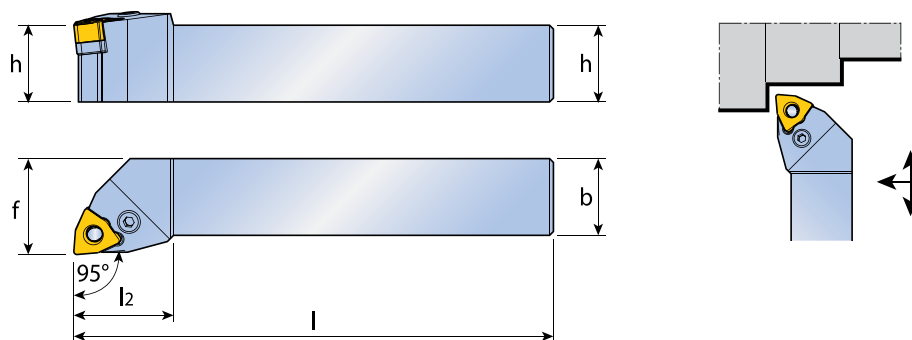
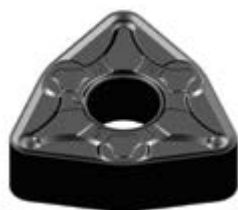

Державка Holder	Размеры Dimensions				Комплектация Spare parts					Режущая пластина Cutting insert
	h	b	f	l	Винт рычага Lever screw	Пластина опорная Shim	Рычаг Lever	Втулка Shim pin	Ключ Key	
PWLNR/L 1616 H0604	16	16	20	100	US 46	WNU 060308	PU 01	NT 04	H3.0	WNM.0604..
2020 K0604	20	20	25	125	US 34	WNU 060308	PU 01	NT 04	H3.0	WNM.0604..
2020 K08	20	20	25	125	US 42	WNU 080312	PU 02	NT 05	H4.0	WNM.0804..
2525 M08	25	25	32	150	US 35	WNU 080312	PU 02	NT 05	H4.0	WNM.0804..
3225 P08	32	25	32	170	US 35	WNU 080312	PU 02	NT 05	H4.0	WNM.0806..

S-PCLNR/L

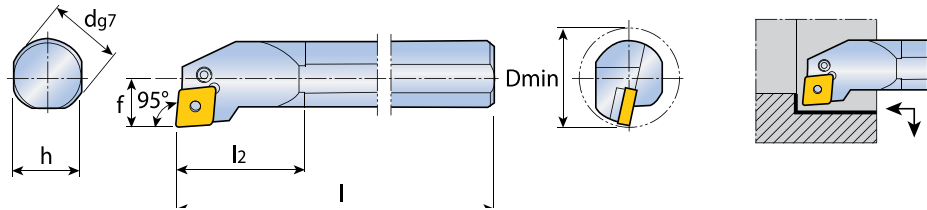

Державка Holder	Размеры Dimensions					Комплектация Spare parts					Режущая пластина Cutting insert
	d	h	l	f	Dmin	Винт рычага Lever screw	Пластина опорная Shim	Рычаг Lever	Втулка Shim pin	Ключ Key	
S16R PCLNR/L 09	16	15	200	11	20	LCS 2B	-	LCL 3B	-	H2.0	CNM. 0903..
S20S PCLNR/L 09	20	18	250	13	25	LCS 2B	-	LCL 3B	-	H2.0	CNM. 0903..
S25T PCLNR/L 12	25	23	300	17	32	US 46	-	PU 32	-	H3.0	CNM. 1204..
S32T PCLNR/L 12	32	30	300	22	40	US 41	CNU 120312	PU 02	NT 05	H4.0	CNM. 1204..
S32U PCLNR/L 16	32	30	350	22	40	US 38	CNU 190416	PU 05	NT 06	H5.0	CNM. 1906..
S40T PCLNR/L 12	40	38	300	27	50	US 35	CNU 120312	PU 02	NT 05	H4.0	CNM. 1204..
S40T PCLNR/L 16	40	38	300	27	50	US 40	CNU 150312	PU 04	NT 07	H4.0	CNM. 1606..
S50U PCLNR/L 16	50	47	350	35	63	US 36	CNU 150312	PU 04	NT 07	H4.0	CNM. 1606..
S50U PCLNR/L 19	50	47	350	35	63	US 38	CNU 190416	PU 05	NT 06	H5.0	CNM. 1906..
S60V PCLNR/L 16	60	57	400	43	80	US 36	CNU 150312	PU 04	NT 07	H4.0	CNM. 1606..
S60V PCLNR/L 19	60	57	400	43	80	US 38	CNU 190416	PU 05	NT 06	H5.0	CNM. 1906..

S-PDUNR/L

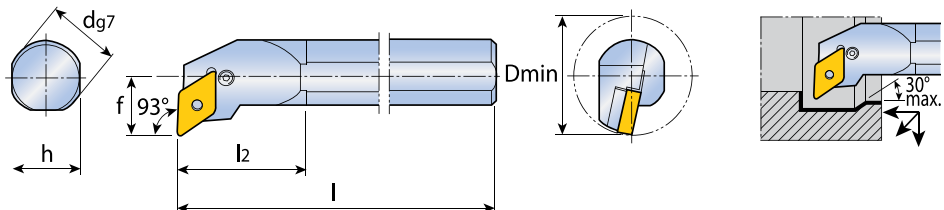

Державка Holder	Размеры Dimensions					Комплектация Spare parts					Режущая пластина Cutting insert
	d	h	l	f	Dmin	Винт рычага Lever screw	Пластина опорная Shim	Рычаг Lever	Втулка Shim pin	Ключ Key	
S20Q PDUNR 11					25		-	PU 3611	-	H2.0	DNM. 1104..
S25T PDUNR/L 11	25	23	300	17	32	PS 0512	-	PU 3611	-	H2.0	DNM. 1104..
S32T PDUNR/L 11	32	30	300	22	40	PS 0616	PDN 110308	PU 3512	NT 5153	H2.5	DNM. 1104..
S32T PDUNR/L 1504	32	30	300	22	40	US 41	-	PU 03	NT 05	H4.0	DNM. 1504..
S40T PDUNR/L 15	40	37	300	27	50	US 41	DNU 150308 DNU 150408	PU 03	NT 05, NT 15	H4.0	DNM. 1504../1506
S50U PDUNR/L 15	50	47	350	35	63	US 41	DNU 150308 DNU 150408	PU 03	NT 05, NT 15	H4.0	DNM. 1504../1506
S60V PDUNR/L 15	60	57	400	43	80	US 41	DNU 150308 DNU 150408	PU 03	NT 05, NT 15	H4.0	DNM. 1504../1506
S40T PDUNR/L 15	40	37	300	27	50	US 41	DNU 150308 DNU 150408	PU 03	NT 05, NT 15	H4.0	DNM. 1504../1506
S50U PDUNR/L 15	50	47	350	35	63	US 41	DNU 150308 DNU 150408	PU 03	NT 05, NT 15	H4.0	DNM. 1504../1506
S60V PDUNR/L 15	60	57	400	43	80	US 41	DNU 150308 DNU 150408	PU 03	NT 05, NT 15	H4.0	DNM. 1504../1506

S-PSKNR/L

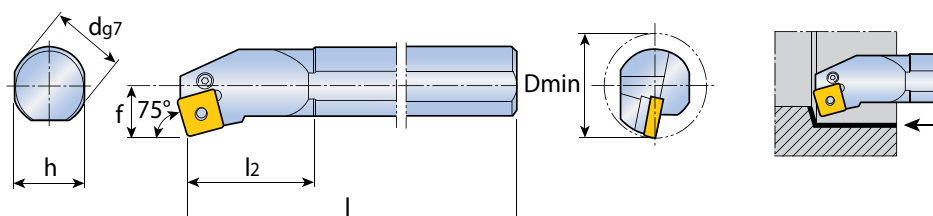

Державка Holder	Размеры Dimensions					Комплектация Spare parts					Режущая пластина Cutting insert
	d	h	l	f	Dmin	Винт рычага Lever screw	Пластина опорная Shim	Рычаг Lever	Втулка Shim pin	Ключ Key	
S32U PSKNR/L 12	32	30	350	22	40	US 41	SNU 120312	PU 02	NT 05	H4.0	SNM.1204..
S40T PSKNR/L 12	40	38	300	27	50	US 35	SNU 120312	PU 02	NT 05	H4.0	SNM.1204..
S40T PSKNR/L 15	40	38	300	27	50	US 40	SNU 150312	PU 04	NT 07	H4.0	SNM.1506..
S50U PSKNR/L 15	50	48,5	350	35	63	US 36	SNU 150312	PU 04	NT 07	H4.0	SNM.1506..
S50U PSKNR/L 19	50	48,5	350	35	63	US 38	SNU 190416	PU 05	NT 06	H5.0	SNM.1906..
S60T PSKNR/L 15	60	58,5	400	43	80	US 36	SNU 150312	PU 04	NT 07	H4.0	SNM.1506..
S60T PSKNR/L 19	60	58,5	400	43	80	US 38	SNU 190416	PU 05	NT 06	H5.0	SNM.1906..

S-PTFNR/L

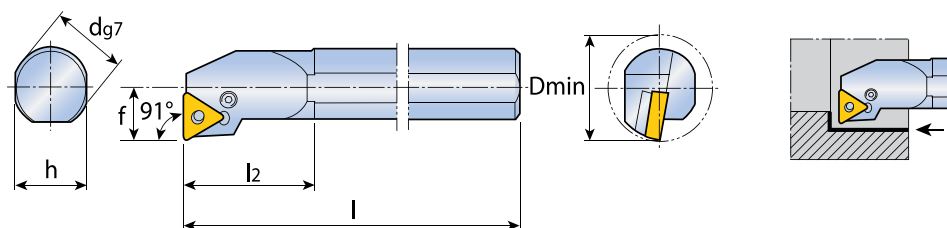

Державка Holder	Размеры Dimensions					Комплектация Spare parts					Режущая пластина Cutting insert
	d	h	l	f	Dmin	Винт рычага Lever screw	Пластина опорная Shim	Рычаг Lever	Втулка Shim pin	Ключ Key	
S25R PTFNR/L 16	25	23	200	17	32	US 46	TNU 160308	PU 01	NT 04	H3.0	TNM. 1604..
S32S PTFNR/L 16	32	30	250	22	44	US 34	TNU 160308	PU 01	NT 04	H3.0	TNM. 1604..
S40T PTFNR/L 22	40	38	300	27	50	US 35	TNU 220312	PU 02	NT 05	H4.0	TNM. 2204..

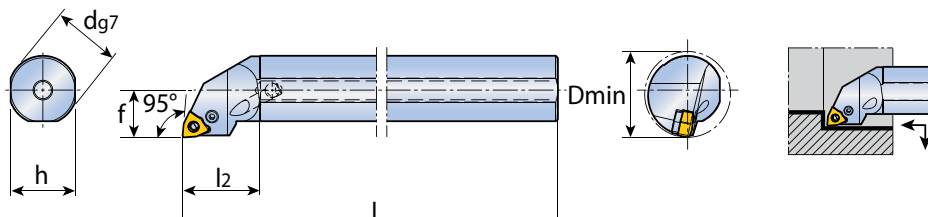
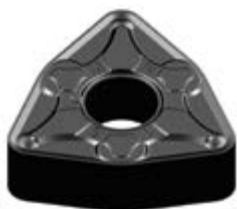
S-PWLNRL

Державка Holder	Размеры Dimensions					Комплектация Spare parts					Режущая пластина Cutting insert
	d	h	l	f	Dmin	Винт рычага Lever screw	Пластина опорная Shim	Рычаг Lever	Втулка Shim pin	Ключ Key	
S25T PWLNRL 0604	25	23	300	17	32	US 46	WNU 060308	PU 01	NT 04	H3.0	WNM.0604..
S25T PWLNRL 08	25	23	300	17	32	US 46	-	PU 32	-	H3.0	WNM.0804..
S32S PWLNRL 0604	32	30	250	22	40	US 46	WNU 060308	PU 01	NT 04	H3.0	WNM.0604..
S32U PWLNRL 08	32	30	350	22	40	US 41	WNU 080312	PU 02	NT 05	H4.0	WNM.0804..
S40T PWLNRL 08	40	38	300	27	50	US 35	WNU 080312	PU 02	NT 05	H4.0	WNM.0804..
S50U PWLNRL 08	50	48,5	350	35	63	US 35	WNU 080312	PU 02	NT 05	H4.0	WNM.0804..
S60V PWLNRL 08	60	58,5	400	43	80	US 35	WNU 080312	PU 02	NT 05	H4.0	WNM.0804..

SCACR/L

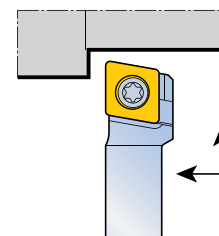
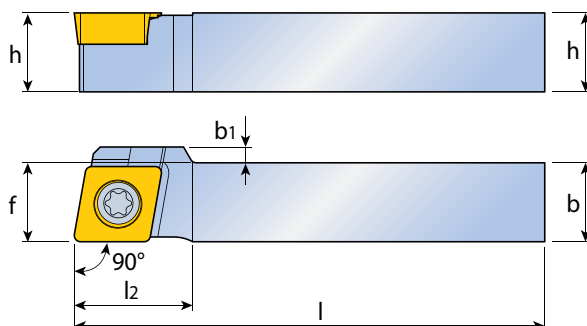
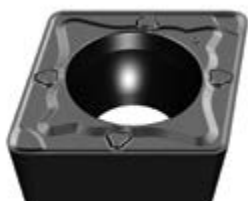

Державка Holder	Размеры Dimensions				Комплектация Spare parts					Режущая пластина Cutting insert
	h	b	f	l	Винт зажимной Clamp screw	Пластина опорная Shim	Винт опорной пластины Shim pin	Отвёртка Screwdriver	Ключ Key	
SCACR/L 0808 D06	8	8	8,5	60	SO 25065I	-	-	T 7	-	CC.. 0602..
1010 E06	10	10	10,5	70	SO 25065I	-	-	T 7	-	CC.. 0602..
1212 F09	12	12	12,5	80	SO 35080I	-	-	T 15	-	CC.. 09T3..
1616 H09	16	16	16,5	100	SO 35080I	-	-	T 15	-	CC.. 09T3..

SCLCR/L

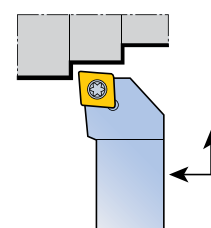
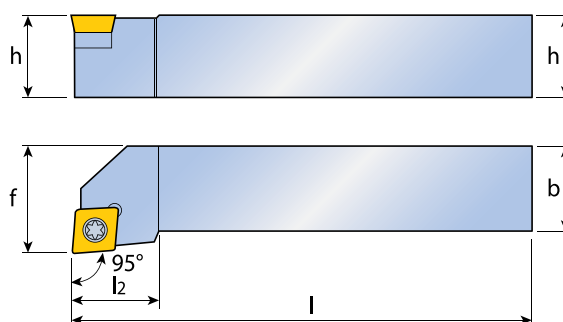
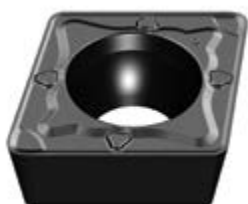

Державка Holder	Размеры Dimensions				Комплектация Spare parts					Режущая пластина Cutting insert
	h	b	f	l	Винт зажимной Clamp screw	Пластина опорная Shim	Винт опорной пластины Shim screw	Отвёртка Wrench	Ключ Key	
SCLCR/L 0808 D06	8	8	10	60	US 2506-T7P	-	-	T 7	-	CC.. 0602..
1010 E06	10	10	16	70	US 2506-T7P	-	-	T 7	-	CC.. 0602..
1212 F09	12	12	20	80	US 3510-T15P	-	-	T 15	-	CC.. 09T3..
1616 H09	16	16	20	100	US 3510-T15P	-	-	T 15	-	CC.. 09T3..
2020 K09	20	20	25	125	US 3510-T15P	-	-	T 15	-	CC.. 09T3..
2020 K12	20	20	25	125	US 4512-T15P	SCN 120304	MS 4510-S5	T 20	H 5.0	CC.. 1204..
2525 M09	25	25	32	150	US 3510-T15P	-	-	T 15	-	CC.. 09T3..
2525 M12	25	25	32	150	US 4512-T15P	SCN 120304	MS 4510-S5	T 20	H 5.0	CC.. 1204..

SDJCR/L

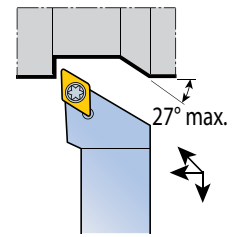
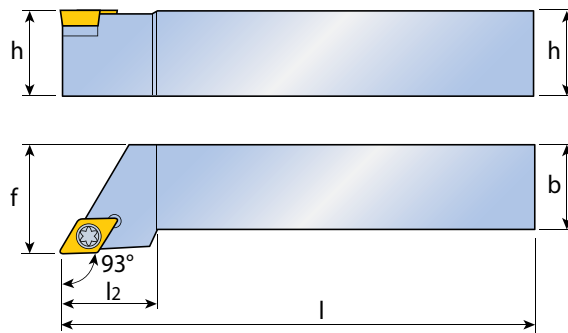

Державка Holder	Размеры Dimensions					Комплектация Spare parts					Режущая пластина Cutting insert
	h	b	f	l	Винт зажимной Clamp screw	Пластина опорная Shim	Винт опорной пластины Shim screw	Отвёртка Wrench	Ключ Key		
SDJCR/L 0808 D07	8	8	10	60	SO 250651	-	-	T 7	-	DC.. 0702..	
1010 E07	10	10	12	70	SO 250651	-	-	T 7	-	DC.. 0702..	
1212 F07	12	12	16	80	SO 250651	-	-	T 7	-	DC.. 0702..	
1212 F11	12	12	16	80	SO 350801	-	-	T 15	-	DC.. 11T3..	
1616 H11	16	16	20	100	SO 350801	-	-	T 15	-	DC.. 11T3..	
2020 K11	20	20	25	125	SO 351241	SDN 110304	SO 50090S	T 15	H 3.5	DC.. 11T3..	
2525 M11	20	20	32	150	SO 351241	SDN 110304	SO 50090S	T 15	H 3.5	DC.. 11T3..	

SDNCN

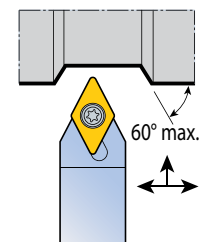
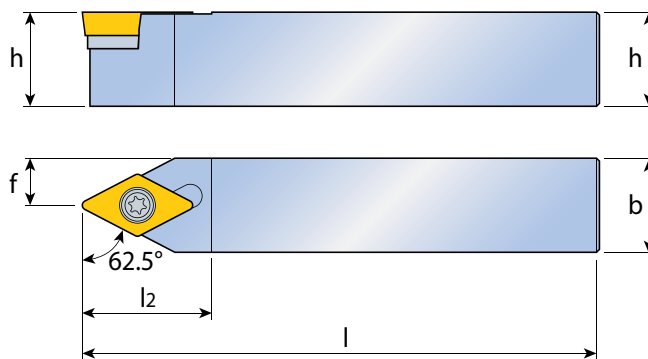

Державка Holder	Размеры Dimensions					Комплектация Spare parts					Режущая пластина Cutting insert
	h	b	f	l	Винт зажимной Clamp screw	Пластина опорная Shim	Винт опорной пластины Shim screw	Отвёртка Wrench	Ключ Key		
SDNCN 0808 D07	8	8	4	60	SO 250651	-	-	T 7	-	DC.. 0702..	
1010 E07	10	10	5	70	SO 250651	-	-	T 7	-	DC.. 0702..	
1212 F07	12	12	6	80	SO 250651	-	-	T 7	-	DC.. 0702..	
1212 F11	12	12	6	80	SO 350801	-	-	T 15	-	DC.. 11T3..	
1616 H11	16	16	8	100	SO 350801	-	-	T 15	-	DC.. 11T3..	
2020 K11	20	20	10	125	SO 350801	SDN 110304	SO 50090S	T 15	H 3.5	DC.. 11T3..	
2525 M11	25	25	12,5	150	SO 350801	SDN 110304	SO 50090S	T 15	H 3.5	DC.. 11T3..	

SRDCN

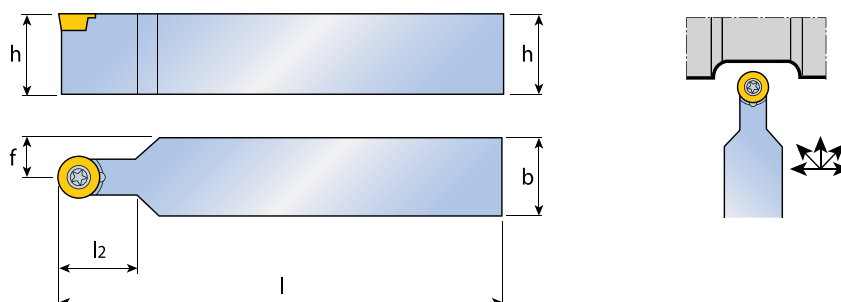

Державка Holder	Размеры Dimensions					Комплектация Spare parts					Режущая пластина Cutting insert
	h	b	f	l	Винт зажимной Clamp screw	Пластина опорная Shim	Винт опорной пластины Shim screw	Отвёртка Wrench	Ключ Key		
SRDCN 1212 F06	12	12	6	80	US 2506-T7P	-	-	T7	-	RC.. 0602M0	
1616 H06	16	16	8	100	US 2506-T7P	-	-	T7	-	RC.. 0602M0	
2020 K08	20	20	10	125	US 3007-T09P	-	-	T 9	-	RC.. 0803M0	
2020 K10	20	20	10	125	US 4011-T15P	-	-	T15	-	RC.. 10T3M0	
2525 M10	25	25	12,5	150	US 4011-T15P	-	-	T15	-	RC.. 10T3M0	
2525 M12	25	25	12,5	150	US 4011-T15P	-	-	T15	-	RC.. 1204M0	
2525 P16	25	25	12,5	150	US 5018-T20P	SRN 16T3M0	MS 5015-S5	T15	H 5.0	RC.. 1606M0	
3225 P10	32	25	17,5	170	US 4011-T15P	-	-	T15	-	RC.. 10T3M0	
3225 P12	32	25	18,5	170	US 4011-T15P	-	-	T15	-	RC.. 1204M0	
3225 P16	32	25	20,5	170	US 5018-T20P	SRN 16T3M0	MS 5015-S5	T15	H 5.0	RC.. 1606M0	

SRSCR/L

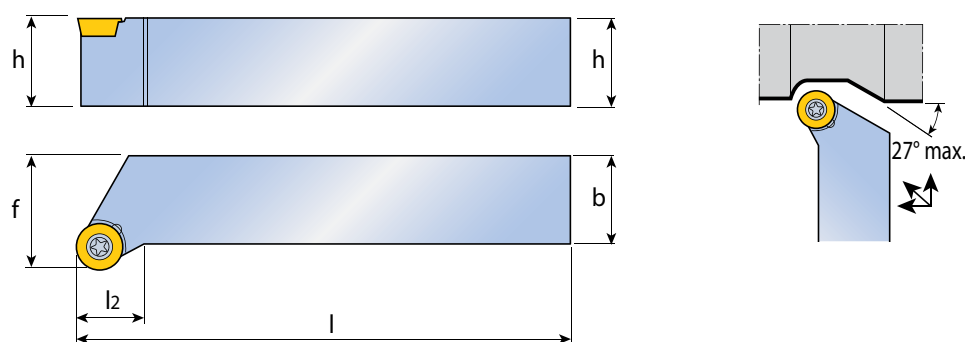

Державка Holder	Размеры Dimensions					Комплектация Spare parts					Режущая пластина Cutting insert
	h	b	f	l	Винт зажимной Clamp screw	Пластина опорная Shim	Винт опорной пластины Shim screw	Отвёртка Wrench	Ключ Key		
SRSCR/L 1212 F06	12	12	16	80	SO 2506S1	-	-	T 7	-	RC.. 0602M0	
1616 H06	16	16	20	100	SO 2506S1	-	-	T 7	-	RC.. 0602M0	
2020 K08	20	20	25	125	SO 300801	-	-	T 9	-	RC.. 0803M0	
2020 K10	20	20	25	125	TS 400971	-	-	T 15	-	RC.. 10T3M0	
2525 M10	25	25	32	150	TS 400971	-	-	T 15	-	RC.. 10T3M0	
2525 M12	32	25	32	150	SO 400501	-	-	T 15	-	RC.. 1204M0	
3225 P10	32	25	32	170	TS 400971	-	-	T 15	-	RC.. 10T3M0	
3225 P12	32	25	32	170	SO 400501	-	-	T 15	-	RC.. 1204M0	
3225 P16	32	25	32	170	US 5018-T20P	SRN 16T3M0	MS 5015	T20	H 5.0	RC.. 1606M0	

SSBCR/L

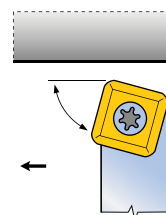
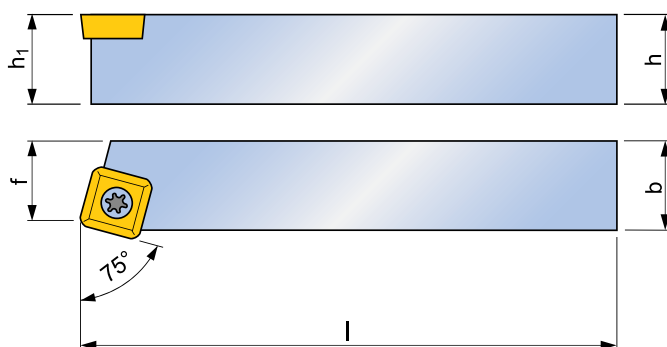

Державка Holder	Размеры Sizes					Комплектация Component parts					Режущая пластина Cutting insert
	h	b	f	l	Винт зажимной Clamp screw	Пластина опорная Shim	Винт опорной пластины Shim screw	Отвёртка Wrench	Ключ Key		
SSBCR/L 1212 F09	12	12	11	80	US 3510-T15P	-	-	T15	-	SC.. 09T3..	
1616 H09	16	16	13	100	US 3510-T15P	-	-	T15	-	SC.. 09T3..	
2020 K12	20	20	17	125	US 4512-T15P	SSN 120304	MS 4510-S5	T20	H 5.0	SC.. 1204..	
2525 M12	25	25	22	150	US 4512-T15P	SSN 120304	MS 4510-S5	T20	H 5.0	SC.. 1204..	
4040 S25	40	40	35	250	US 8025-T30P	SSN 250620	MS 8020-S8	T30	H 5.0	SC.. 2509..	
5050 T25	50	50	43	300	US 8025-T30P	SSN 250620	MS 8020-S8	T30	H 5.0	SC.. 2509..	
5050 T38	50	50	43	300	US 8025-T30P	SSN 380620	MS 8020-S8	T30	H 5.0	SC.. 3809..	
6060 V38	60	60	53	400	US 8025-T30P	SSN 380620	MS 8020-S8	T30	H 5.0	SC.. 3809..	

SSDCN

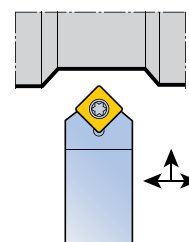
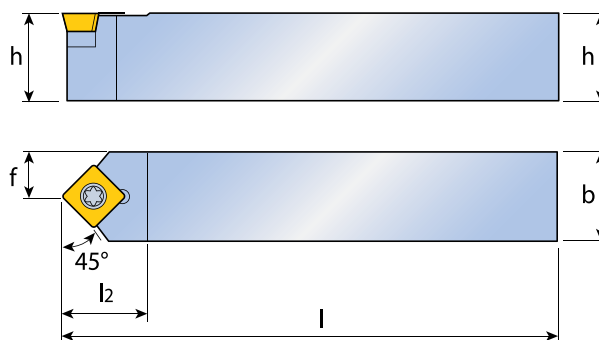

Державка Holder	Размеры Dimensions					Комплектация Spare parts					Режущая пластина Cutting insert
	h	b	f	l	Винт зажимной Clamp screw	Пластина опорная Shim	Винт опорной пластины Shim screw	Отвёртка Wrench	Ключ Key		
SSDCN 1212 F09	12	12	6	80	US 3510-T15P	-	-	T15	-	SC.. 09T3..	
1616 H09	16	16	8	100	US 3510-T15P	-	-	T15	-	SC.. 09T3..	
2020 K12	20	20	10	125	US 4512-T15P	SSN 120304	MS 4510-S5	T20	H 5.0	SC.. 1204..	
2525 M12	25	25	12,5	150	US 4512-T15P	SSN 120304	MS 4510-S5	T20	H 5.0	SC.. 1204..	

STFCR/L

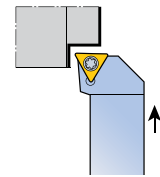
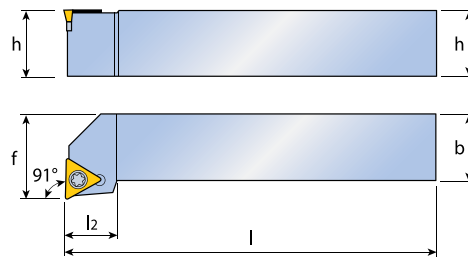
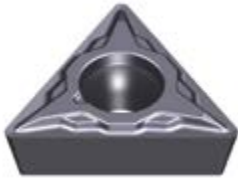

Державка Holder	Размеры Dimensions				Комплектация Spare parts					Режущая пластина Cutting insert
	h	b	f	l	Винт зажимной Clamp screw	Пластина опорная Shim	Винт опорной пластины Shim screw	Отвёртка Wrench	Ключ Key	
STFCR/L 1616 H11	16	16	20	100	US 2506-T7P	-	-	T7	-	ТС.. 1102..
2020 K16	20	20	25	125	US 3510-T15P	STN 160308	MS 3510-S3.5	T15	H 3.5	ТС.. 16T3..
2525 M16	25	25	32	150	US 3510-T15P	STN 160308	MS 3510-S3.5	T15	H 3.5	ТС.. 16T3..

SVHB(C)R/L

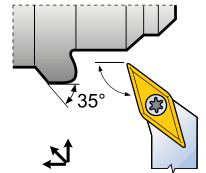
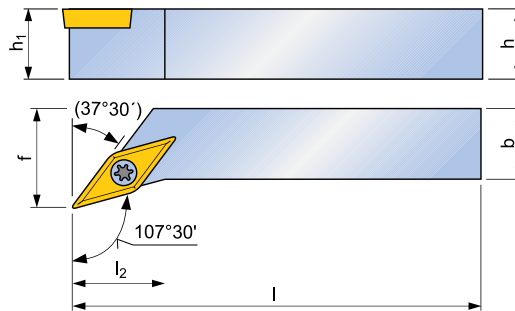
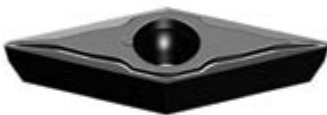

Державка Holder	Размеры Sizes				Комплектация Component parts					Режущая пластина Cutting insert
	h	b	f	l	Винт зажимной Clamp screw	Пластина опорная Shim	Винт опорной пластины Shim screw	Отвёртка Wrench	Ключ Key	
SVHB(C)R/L 1616 H11	16	16	20	100	US 2506-T7P	-	-	T7	-	VB.. 1103.. VC.. 1103..
2020 K16	20	20	25	125	US 3510-T15P	SVN 160304	MS 3510-S3.5	T15	H 3.5	VB.. 1604.. VC.. 1604..
2525 M16	25	25	32	150	US 3510-T15P	SVN 160304	MS 3510-S3.5	T15	H 3.5	VB.. 1604.. VC.. 1604..
3225 P16	32	25	32	170	US 3510-T15P	SVN 160304	MS 3510-S3.5	T15	H 3.5	VB.. 1604.. VC.. 1604..

SVJB(C)R/L

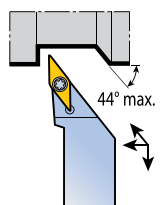
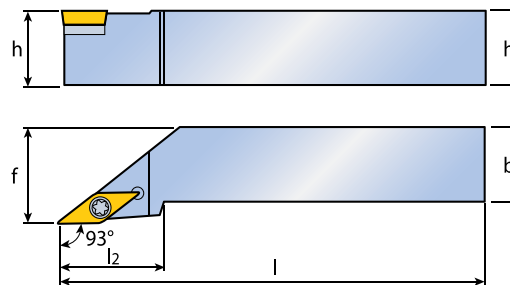
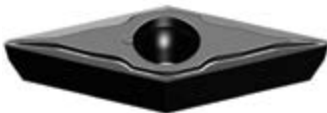

Державка Holder	Размеры Dimensions				Комплектация Spare parts					Режущая пластина Cutting insert
	h	b	f	l	Винт зажимной Clamp screw	Пластина опорная Shim	Винт опорной пластины Shim screw	Отвёртка Wrench	Ключ Key	
SVJB(C)R/L 1212 F11	12	12	16	80	US 2506-T7P	-	-	T7	-	VB.. 1103.. VC.. 1103..
1616 H11	16	16	20	100	US 2506-T7P	-	-	T7	-	VB.. 1103.. VC.. 1103..
2020 K16	20	20	25	125	US 3510-T15P	SVN 160304	MS 3510-S3.5	T15	H 3.5	VB.. 1604.. VC.. 1604..
2525 M16	25	25	32	150	US 3510-T15P	SVN 160304	MS 3510-S3.5	T15	H 3.5	VB.. 1604.. VC.. 1604..
3225 P16	32	25	32	170	US 3510-T15P	SVN 160304	MS 3510-S3.5	T15	H 3.5	VB.. 1604.. VC.. 1604..

SVPB(C)R/L

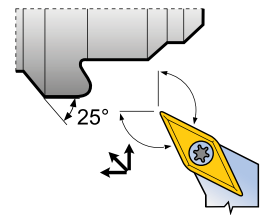
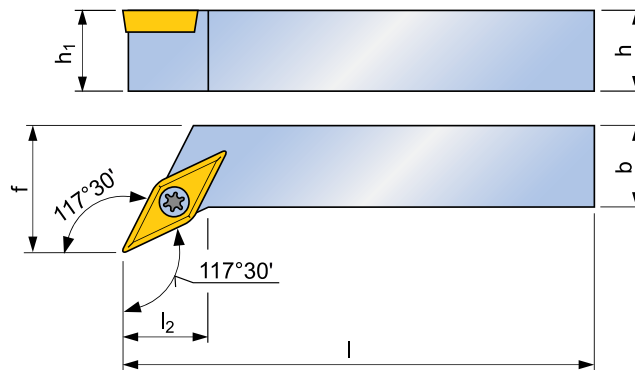

Державка Holder	Размеры Dimensions				Комплектация Spare parts					Режущая пластина Cutting insert
	h	b	f	l	Винт зажимной Clamp screw	Пластина опорная Shim	Винт опорной пластины Shim screw	Отвёртка Wrench	Ключ Key	
SVPB(C)R/L 2020 K16	20	20	25	125	US 3510-T15P	SVN 160304	MS 3510-S3.5	T 15	H 3.5	VB.. 1604.. VC.. 1604..
2525 M16	25	25	32	150	US 3510-T15P	SVN 160304	MS 3510-S3.5	T 15	H 3.5	VB.. 1604.. VC.. 1604..
3225 P16	32	25	32	170	US 3510-T15P	SVN 160304	MS 3510-S3.5	T 15	H 3.5	VB.. 1604.. VC.. 1604..

SVVB(C)N

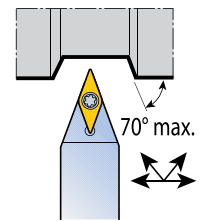
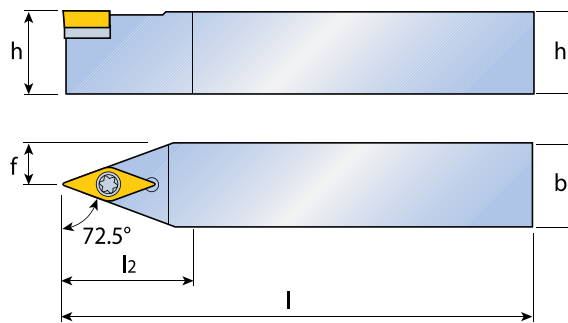

Державка Holder	Размеры Dimensions				Комплектация Spare parts					Режущая пластина Cutting insert
	h	b	f	l	Винт зажимной Clamp screw	Пластина опорная Shim	Винт опорной пластины Shim screw	Отвёртка Wrench	Ключ Key	
SVVB(C)N 1212 F11	12	12	6	80	US 2506-T7P	-	-	T7	-	VB.. 1103.. VC.. 1103..
1616 H11	16	16	8	100	US 2506-T7P	-	-	T7	-	VB.. 1103.. VC.. 1103..
2020 K11	20	20	10	125	US 2506-T7P	-	-	T7	-	VB.. 1103.. VC.. 1103..
2020 K16	20	20	10	125	US 3510-T15P	SVN 160304	MS 3510-S3.5	T15	H 3.5	VB.. 1604.. VC.. 1604..
2525 M16	25	25	12,5	150	US 3510-T15P	SVN 160304	MS 3510-S3.5	T15	H 3.5	VB.. 1604.. VC.. 1604..
3225 P16	32	25	12,5	170	US 3510-T15P	SVN 160304	MS 3510-S3.5	T15	H 3.5	VB.. 1604.. VC.. 1604..

S-SCKCR/L

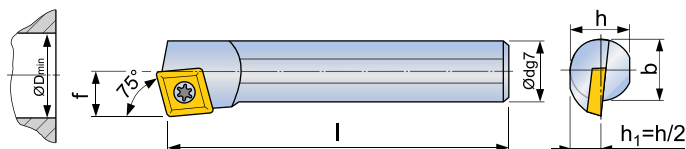

Державка Holder	Размеры Dimensions					Комплектация Spare parts					Режущая пластина Cutting insert
	d	h	l	f	Dmin	Винт зажимной Clamp screw	Пластина опорная Shim	Винт опорной пластины Shim screw	Отвёртка Wrench	Ключ Key	
S08F SCKCRIL 06	8	7,2	80	6	11	US 2506-T7P	-	-	T 7	-	CC.. 0602..
S10H SCKCRIL 06	10	9	100	7	13	US 2506-T7P	-	-	T 7	-	CC.. 0602..
S12K SCKCRIL 06	12	11	125	9	16	US 2506-T7P	-	-	T 7	-	CC.. 0602..
S16M SCKCRIL 09	16	14,5	150	11	20	US 3510-T15P	-	-	T 15	-	CC.. 09T3..
S20S SCKCRIL 09	20	18,5	250	13	25	US 3510-T15P	-	-	T 15	-	CC.. 09T3..
S25T SCKCRIL 09	25	23	300	17	32	US 3510-T15P	-	-	T 15	-	CC.. 09T3..
S32U SCKCRIL 12	32	30	350	22	40	US 4512-T15P	SCN 120304	MS 4510-S5	T20	H 5.0	CC.. 1204..

S-SCLCR/L

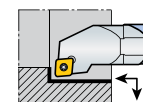
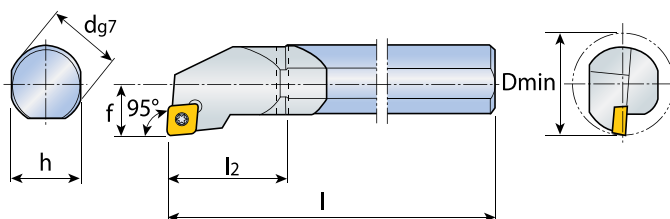
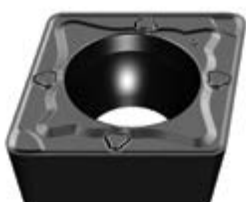

Державка Holder	Размеры Dimensions					Комплектация Spare parts					Режущая пластина Cutting insert
	d	h	l	f	Dmin	Винт зажимной Clamp screw	Пластина опорная Shim	Винт опорной пластины Shim screw	Отвёртка Wrench	Ключ Key	
S08F SCLCRIL 06	8	7	80	5	10	US 2506-T7P	-	-	T7	-	CC.. 0602..
S10H SCLCRIL 06	10	9	100	6	12	US 2506-T7P	-	-	T7	-	CC.. 0602..
S12K SCLCRIL 06	12	11	125	9	16	US 2506-T7P	-	-	T7	-	CC.. 0602..
S16M SCLCRIL 09	16	15	150	11	20	US 3510-T15P	-	-	T15	-	CC.. 09T3..
S20Q SCLCRIL 09	20	19	180	12	25	US 3510-T15P	-	-	T15	-	CC.. 09T3..
S25T SCLCRIL 09	25	23	300	17	32	US 3510-T15P	-	-	T15	-	CC.. 09T3..
S32U SCLCRIL 12	32	30	350	22	40	US 4512-T15P	SCN 120304	MS 4510-S5	T20	H 5.0	CC.. 1204..

S-SDUCR/L

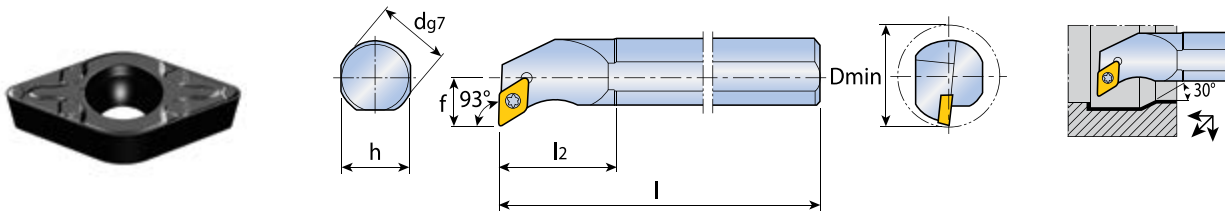

Державка Holder	Размеры Dimensions					Комплектация Spare parts					Режущая пластина Cutting insert
	d	h	l	f	Dmin	Винт зажимной Clamp screw	Пластина опорная Shim	Винт опорной пластины Shim screw	Отвёртка Wrench	Ключ Key	
S10H SDUCRIL 07	10	9	100	7	13	US 2506-T7P	-	-	T7	-	DC.. 0702..
S12K SDUCRIL 07	12	11	125	9	16	US 2506-T7P	-	-	T7	-	DC.. 0702..
S16M SDUCRIL 07	16	15	150	11	20	US 2506-T7P	-	-	T7	-	DC.. 0702..
S20S SDUCRIL 11	20	19	200	13	25	US 3510-T15P	-	-	T15	-	DC.. 11T3..
S25T SDUCRIL 11	25	24	300	17	32	US 3510-T15P	-	-	T15	-	DC.. 11T3..
S32U SDUCRIL 11	32	30	350	22	40	US 3510-T15P	SDN 110304	MS 3510-S3.5	T15	H 3.5	DC.. 11T3..

S-SDZCR/L

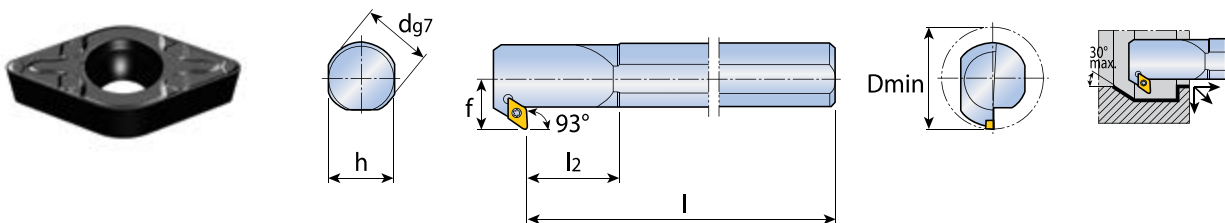

Державка Holder	Размеры Dimensions					Комплектация Spare parts					Режущая пластина Cutting insert
	d	h	l	f	Dmin	Винт зажимной Clamp screw	Пластина опорная Shim	Винт опорной пластины Shim screw	Отвёртка Wrench	Ключ Key	
S16M SDZCRIL 07	16	14,5	150	17	20	US 2506-T7P	-	-	T7	-	DC.. 0702..
S20Q SDZCRIL 11	20	18	180	22	35	US 3510-T15P	-	-	T15	-	DC.. 11T3..
S25R SDZCRIL 11	25	23	200	27	42	US 3510-T15P	-	-	T15	-	DC.. 11T3..
S32S SDZCRIL 11	32	30	250	35	53	US 3510-T15P	SDN 110304	MS 3510-S3.5	T15	H 3.5	DC.. 11T3..
S40T SDZCRIL 11	40	38	300	43	65	US 3510-T15P	SDN 110304	MS 3510-S3.5	T15	H 3.5	DC.. 11T3..

S-SSSCR/L

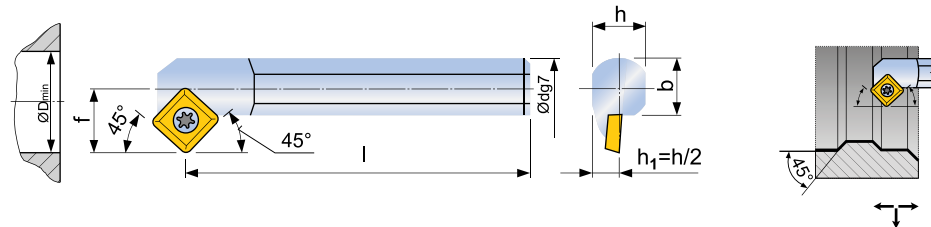

Державка Holder	Размеры Dimensions					Комплектация Spare parts					Режущая пластина Cutting insert
	d	h	l	f	Dmin	Винт зажимной Clamp screw	Пластина опорная Shim	Винт опорной пластины Shim screw	Отвёртка Wrench	Ключ Key	
S20S SSSCR/L 09	20	18	200	13	25	US 3510-T15P	-	-	T15	-	SC.. 09T3..
S25T SSSCR/L 09	25	23	300	17	32	US 3510-T15P	-	-	T15	-	SC.. 09T3..
S32U SSSCR/L 09	32	30	350	22	40	US 3510-T15P	-	-	T15	-	SC.. 09T3..
S32U SSSCR/L 12	32	30	350	22	40	US 4512-T15P	SSN 120304	MS 4510-S5	T20	H 3.5	SC.. 1204..

S-STFCR/L

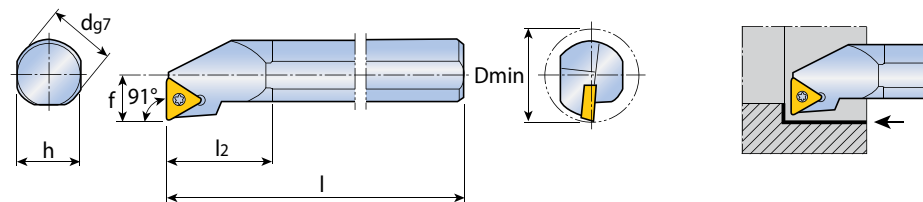
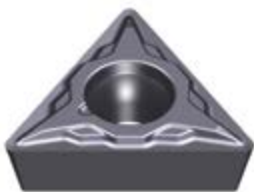

Державка Holder	Размеры Dimensions					Комплектация Spare parts					Режущая пластина Cutting insert
	d	h	l	f	Dmin	Винт зажимной Clamp screw	Пластина опорная Shim	Винт опорной пластины Shim screw	Отвёртка Wrench	Ключ Key	
S10H STFCR/L 11	10	9,5	100	7	13	US 2506-T7P	-	-	T 7	-	TC.. 1102..
S12K STFCR/L 11	12	11	125	9	16	US 2506-T7P	-	-	T 7	-	TC.. 1102..
S16M STFCR/L 11	16	15	150	11	20	US 2506-T7P	-	-	T 7	-	TC.. 1102..
S20Q STFCR/L 11	20	19	180	13	25	US 2506-T7P	-	-	T 7	-	TC.. 1102..
S25T STFCR/L 16	25	23	300	17	32	US 3510-T15P	-	-	T 15	-	TC.. 16T3
S32U STFCR/L 16	32	30	250	22	40	US 3510-T15P	STN 160308	MS 3510-S3.5	T 15	H 3.5	TC.. 16T3

S-SVQB(C)R/L

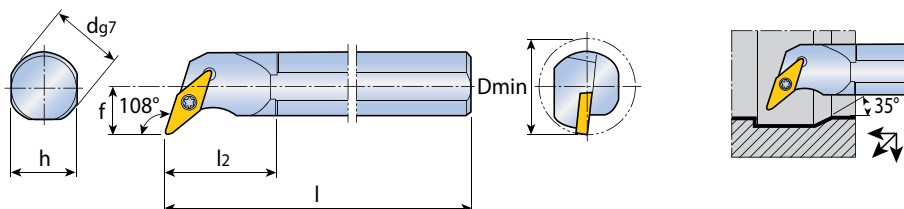

Державка Holder	Размеры Dimensions					Комплектация Spare parts					Режущая пластина Cutting insert
	d	h	l	f	Dmin	Винт зажимной Clamp screw	Пластина опорная Shim	Винт опорной пластины Shim screw	Отвёртка Wrench	Ключ Key	
S16R SVQB(C)R/L 11	16	14,5	200	11	20	US 2506-T7P	-	-	T7	-	VB.. 1103.. VC.. 1103..
S20S SVQB(C)R/L 11	20	18	250	13	25	US 2506-T7P	-	-	T7	-	VB.. 1103.. VC.. 1103..
S25T SVQB(C)R/L 16	25	23	300	16	32	US 3510-T15P	-	-	T15	-	VB.. 1604.. VC.. 1604..
S32U SVQB(C)R/L 16	32	30	350	22	40	US 3510-T15P	SVN 160304	MS 3510-S3.5	T15	H 3.5	VB.. 1604.. VC.. 1604..
S40V SVQB(C)R/L 16	32	31	400	22	40	US 3510-T15P	SVN 160304	MS 3510-S3.5	T15	H 3.5	VB.. 1604.. VC.. 1604..

S-SVUCR/L

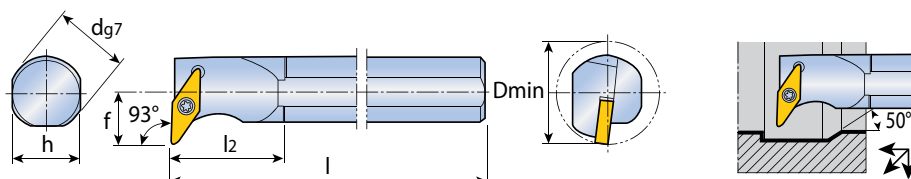

Державка Holder	Размеры Dimensions					Комплектация Spare parts					Режущая пластина Cutting insert
	d	h	l	f	Dmin	Винт зажимной Clamp screw	Пластина опорная Shim	Винт опорной пластины Shim screw	Отвёртка Wrench	Ключ Key	
S16R SVUB(C)R/L 11	16	15	200	11	20	US 2506	-	-	T7	-	VB.. 1103.. VC.. 1103..
S20S SVUB(C)R/L 11	20	18	250	13	25	US 2506-T7P	-	-	T7	-	VB.. 1103.. VC.. 1103..
S25T SVUB(C)R/L 16	25	23	300	19	32	US 3510-T15P	SVN 160304	MS 3510-S3.5	T15	H 3.5	VB.. 1604.. VC.. 1604..
S32U SVUB(C)R/L 16	32	30	350	22	40	US 3510-T15P	SVN 160304	MS 3510-S3.5	T15	H 3.5	VB.. 1604.. VC.. 1604..
S40V SVUB(C)R/L 16	40	37	400	27	50	US 3510-T15P	SVN 160304	MS 3510-S3.5	T15	H 3.5	VB.. 1604.. VC.. 1604..

Система обозначения

Symbol system

ДЕРЖАВКИ ОТРЕЗНЫЕ И КАНАВОЧНЫЕ CUT-OFF AND GROOVING HOLDERS

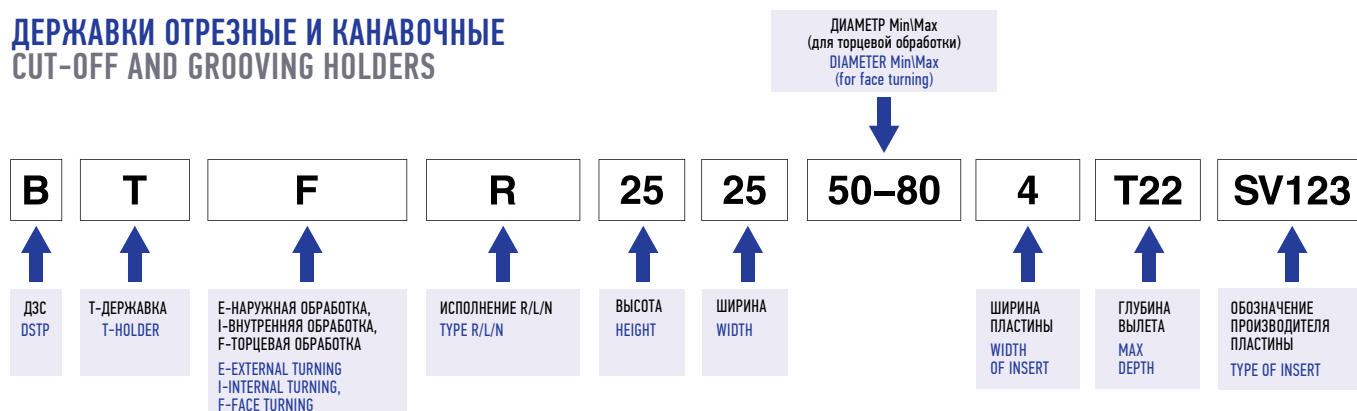

ЛЕЗВИЯ BLADE (EDGE)



BL Отрезные лезвия

BL Cutting blades

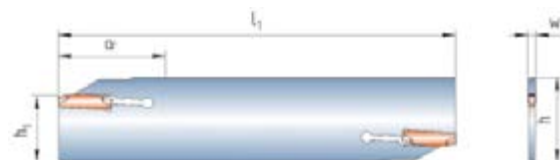

Лезвие Blade	Ширина пластины W Width of insert W	h	L	h1	ar
BL1 26-2S*	2	26	110	21,4	15
BL1 26-3S*	3				25
BL1 26-4S*	4				30
BL2 32-2	2	32	150	25	20
BL2 32-3	3				50
BL2 32-4	4				55
BL2 32-5	5				55
BL2 32-6	6				55
BL2 45-4	4	45	250	38,1	60
BL2 45-5	5				60
BL2 45-6	6				60
BL2 45-7	7				60
BL2 53-9	9	53	260	45,2	80



* Одностороннее лезвие

* One-side blade

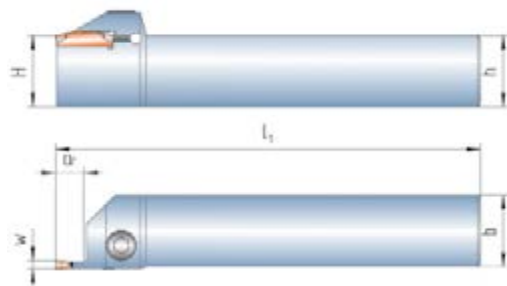

ВТЕР Отрезные державки ВТЕР Cut-off holders



Державка Holder	Ширина пластины W Width of insert W	h=H	B	L	a _r	Винт Screw 	Ключ Key 
ВТЕР/L 1616 2 T08	2	16	16	110	8	M5x10	H4.0
ВТЕР/L 2020 2 T08		20	20	125		M5x14	H4.0
ВТЕР/L 2525 2 T08		25	25	150		M5x20	H4.0
ВТЕР/L 1616 2 T17		16	16	110	17	M5x10	H4.0
ВТЕР/L 2020 2 T17		20	20	125		M5x14	H4.0
ВТЕР/L 2525 2 T17		25	25	150		M5x20	H4.0
ВТЕР/L 1616 3 T09	3	16	16	110	9	M5x10	H4.0
ВТЕР/L 2020 3 T09		20	20	125		M5x14	H4.0
ВТЕР/L 2525 3 T09		25	25	150		M5x20	H4.0
ВТЕР/L 1616 3 T20		16	16	110	20	M5x10	H4.0
ВТЕР/L 2020 3 T20		20	20	125		M5x14	H4.0
ВТЕР/L 2525 3 T20		25	25	150		M5x20	H4.0
ВТЕР/L 1616 4 T10	4	16	16	110	10	M6x10	H5.0
ВТЕР/L 2020 4 T10		20	20	125		M6x14	H5.0
ВТЕР/L 2525 4 T10		25	25	150		M6x18	H5.0
ВТЕР/L 1616 4 T25		16	16	110	25	M6x10	H5.0
ВТЕР/L 2020 4 T25		20	20	125		M6x14	H5.0
ВТЕР/L 2525 4 T25		25	25	150		M6x18	H5.0
ВТЕР/L 2020 5 T12	5	20	20	125	12	M6x18	H5.0
ВТЕР/L 2525 5 T12		25	25	150		M6x18	H5.0
ВТЕР/L 2020 5 T30		20	20	125	30	M6x18	H5.0
ВТЕР/L 2525 5 T30		25	25	150		M6x18	H5.0
ВТЕР/L 2020 6T12	6	20	20	125	12	M6x18	H5.0
ВТЕР/L 2525 6 T12		25	25	150		M6x18	H5.0
ВТЕР/L 2525 6 T32		25	25	150	32	M6x18	H5.0
ВТЕР/L 2525 8 T16	8	25	25	150	16	M6x18	H5.0
ВТЕР/L 3232 8 T16		32	32	170		M6x18	H5.0
ВТЕР/L 2525 8 T36		25	25	150	36	M6x18	H5.0
ВТЕР/L 3232 8 T36		32	32	170		M6x18	H5.0

BTIR Державки для нарезания внутренних канавок

BTIR Internal grooving holders

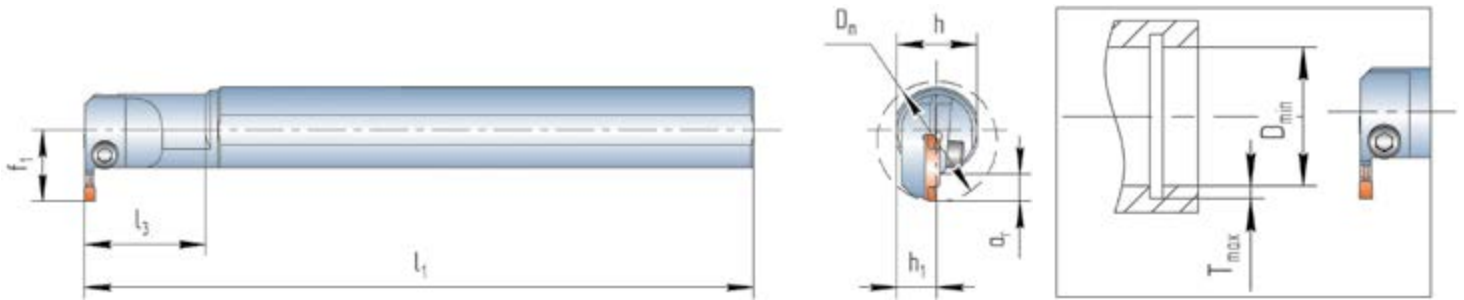

Державка Holder	Габариты Dimensions								
	W	Dm min	ar max	dm	f1	h	h1	l1	l3
BTIR/L 16 1.5 T04	1,5	25	4,5	16	12,5			150	25
BTIR/L 20 1.5 T05		32	5	20	15,25			180	30
BTIR/L 20 2 T05	2	32	5	20	15,25			180	30
BTIR/L 25 2 T07		32	7	25	19,75			200	35
BTIR/L 32 2 T09		40	9,5	32	25,5	30	15	250	45
BTIR/L 20 3 T06	3	32	6	20	15,25			180	30
BTIR/L 25 3 T07		32	7	25	19,75			200	35
BTIR/L 32 3 T09		40	9	32	25,25	30	15	250	45
BTIR/L 40 3 T11		50	11	40	31	37	18,5	300	55
BTIR/L 25 4 T07	4	32	7	25	19,25			200	35
BTIR/L 32 4 T10		40	10	32	26,5	30	15	250	45
BTIR/L 40 4 T11		50	11	40	31	37	18,5	300	55
BTIR/L 50 4 T13		60	13	50	38,25	47	23,5	350	65
BTIR/L 25 5 T08	5	32	8	25	19,75			200	35
BTIR/L 32 5 T11		40	11	32	27	30	15	250	45
BTIR/L 40 5 T11		50	11	40	31	37	18,5	300	55
BTIR/L 50 5 T13		60	13	50	38,25	47	23,5	350	65
BTIR/L 40 6 T11	6	50	11	40	31	37	18,5	300	55
BTIR/L 50 6 T13		60	13	50	38,25	47	23,5	350	65

BTFR Державки для торцевых канавок

BTFR Face grooving holders

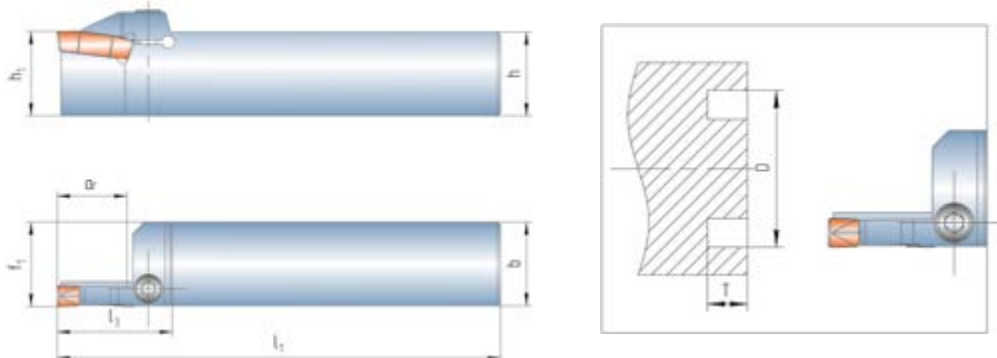

Державка Holder	Габариты Dimensions									
	W	Dm min	Dm max	ar max	b	f1	h	h1	l1	l3
BTFR/L 2525 3444 3 T12	3	34	44	12	25	26	25	25	150	32
BTFR/L 2525 3848 3 T12		38	48	12	25	26	25	25	150	32
BTFR/L 2525 4260 3 T19		42	60	19	25	26	25	25	150	40
BTFR/L 2525 5475 3 T19		54	75	19	25	26	25	25	150	40
BTFR/L 2525 67100 3 T22		67	100	22	25	26	25	25	150	43
BTFR/L 2525 90160 3 T22		90	160	22	25	26	25	25	150	43
BTFR/L 2525 130300 3 T22		130	300	22	25	26	25	25	150	43
BTFR/L 2525 4060 4 T20		4	40	60	20	25	26	25	25	150
BTFR/L 2525 5272 4 T20	52		72	20	25	26	25	25	150	42
BTFR/L 2525 64100 4 T25	64		100	25	25	26	25	25	150	47
BTFR/L 2525 92140 4 T25	92		140	25	25	26	25	25	150	47
BTFR/L 2525 132230 4 T25	132		230	25	25	26	25	25	150	47
BTFR/L 2525 220500 4 T25	220		500	25	25	26	25	25	150	47
BTFR/L 2525 300 4 T25	300		25	25	26	25	25	150	47	
BTFR/L 2525 4070 5 T20	5	40	70	20	25	26	25	25	150	43
BTFR/L 2525 6095 5 T25		60	95	25	25	26	25	25	150	48
BTFR/L 2525 85130 5 T25		85	130	25	25	26	25	25	150	48
BTFR/L 2525 120180 5 T25		120	180	25	25	26	25	25	150	48
BTFR/L 2525 175500 5 T25		175	500	25	25	26	25	25	150	48
BTFR/L 2525 180 5 T20		180		20	25	26	25	25	150	43
BTFR/L 2525 4070 6 T20	6	40	70	20	25	26	25	25	150	44
BTFR/L 2525 58100 6 T25		58	100	25	25	26	25	25	150	49
BTFR/L 2525 88180 6 T25		88	180	25	25	26	25	25	150	49
BTFR/L 2525 168400 6 T25		168	400	25	25	26	25	25	150	49
BTFR/L 2525 220 6 T25		220		25	25	26	25	25	150	49
BTFR/L 2525 5080 8 T25	8	50	80	25	25	26	25	25	150	55
BTFR/L 2525 75150 8 T28		15	150	28	25	26	25	25	150	56
BTFR/L 2525 140400 8 T28		140	400	28	25	26	25	25	150	56

SER

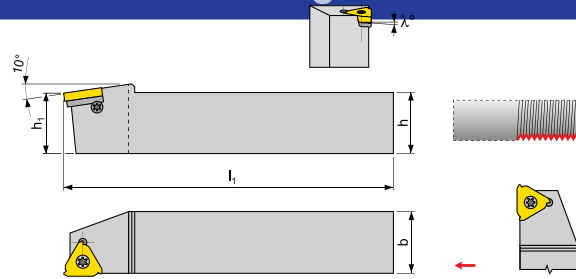

Державка Holder	Размеры Dimensions			Пластина Insert	Винт пластины Insert screw	Опорная пластина Shim	Винт опорной пластины Shim screw	Отвертка Wrench	Ключ Key
	h=h1	b	L						
SER/L 1212 F16	12	12	80	TN 16 ER/L..	US 3510- T15P	PE16+1,5	HS 0304	T15	H 2,5
SER/L 1616 H16	16	16	100						
SER/L 2020 K16	20	20	125						
SER/L 2525 M16	25	25	150						
SER/L 3232 P16	32	32	170						
SER/L 2525 M22-A	25	25	150	TN 22 ER/L..	US 4512- T15P	PE22+1,5	SP 0405	T20	-
SER/L 3225 P22-A	32	25	170						
SER/L 3232 P22-A	32	32	170						
SER/L 4040 R22-A	40	40	200						

SIR

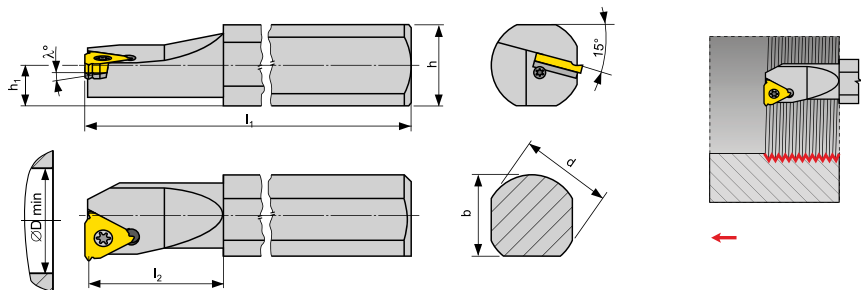

Державка Holder	Размеры Dimensions							Пластина Insert	Винт пластины Insert screw	Опорная пластина Shim	Винт опорной пластины Shim screw	Отвертка Wrench	Ключ Key
	b	d	Dmin	h	h1	l1	l2						
SIR/L 0010 K11-1	14,5	16	13	14	7	125	25	TN 11 NR/L..	US 2506- T07P	-	-	T 07	-
SIR/L 0013 M11-1	14,5	16	16	14	7	150	32						
SIR/L 1416 N16-0	14	16	22	14,5	7,5	160	-	TN 16 NR/L..	US 3510- T15P	PI16+1,5	HS 0304	T15	H 2,5
SIR/L 1820 P16	18,5	20	27	18	9	170	-						
SIR/L 2325 Q16	23,5	25	29	23	11,5	180	-						
SIR/L 2532 S16	30	32	36	25	12,5	250	-	TN 22 NR/L..	US 4512- T15P	PI22+1,5	SP 0405	T20	-
SIR/L 2532 S22-A	30	32	36	25	12,5	250	-						
SIR/L 3240 T22-A	38	40	48	32	16	300	-						

Рычаги

Lever

Форма Form	Обозначение Name	Размеры Dimensions				
		a	b	c	d	h
	LCL3 (PU01)	10,2	3,7	4,4	3,6	12,2
	LCL4 (PU02)	13,2	4,8	6	4,8	13,2
	LCL4A (PU03)	16				14,6
	LCL5 (PU04)	19	6	7,6	6	17,5
	LCL6 (PU05)	20,5	7,4	9,2	7,5	21
	LCL8 (PU06)	25,4	8,6	12,2	8,7	25,4
	LCL16C (PU07)	18,3	4,7	6,2	4,5	18
	LCL20C (PU09)	20,4	6	7,6	5,6	18,8
	LCL25C (PU08)	24,2	7,5	9,4	7,5	24
	LCL32C (PU10)	30	8,6	12,5	8	27

Втулки

Shim pins

Форма Form	Обозначение Name	Размеры Dimensions				
		a	b	c	h	t
	LSP3	6,9	0,9	4,9	3,2	0,3
	LSP3A	5,3				
	LSP4 (NT05)	5,8		6,6	4,3	0,4
	LSP5 (NT07)	8,8	1	8,2	5,4	0,5
	LSP6 (NT06)	11		9,7	6	0,6
	LSP8 (NT08)	12	2	13	9	0,7
	LSP16C	7,7	0,7	6,6	4,3	0,4

Винты US

Lever Screws

Форма Form	Обозначение Name	Размеры Dimensions					
		a	d	h	l	b	c
	PS 0512	M5x0.5	5		12	2	2.5
	PS 0616	M6x0.75	6	10	17	2.5	3
	US34	M6x0.75	6	10,5	19	3	5
	US35	M8X1	8	10,5	22,5	4	7
	US36	M8X1	8	14	26	4	7
	US38	M10X1	10	15	29	5	8
	US39	M10X1	10	19	33	5	8
	US40	M8X1	8	9,5	20,5	4	6
	US41	M8X1	8	9,5	17	4	2,5
	US42	M8X1	8	10	21	4	6
	US46	M6x0.75	6	2.5	13,2	3	6.7
	US47	M12X1	12	18	36	5	10

Винты

Screws

Форма Form	Обозначение Name	Размеры			Dimensions		
		a	d	h	l	c	T
	US 2506-T07P	M2,5X0,45	3,45	2,2	4	60°	T7
	US 3007-T09P	M3X0,5	4.3	2.1	5.4	60°	T9
	US 3510-T15P	M3,5X0,6	5.2	3,5	7	60°	T15
	US 3512-T15P	M3,5X0,6	5.2	3,5	9	60°	T15
	US 4008-T15P	M4X0,7	5.5	3,5	5	60°	T15
	US 4011-T15P	M4X0,7	5.5	3,5	5	60°	T15
	US 4512-T15P	M4,5X0,75	5.5	6.4	4.6	60°	T15
	US 5012-T15P	M5X0,8	7.1	4	8	60°	T15
	US 5018-T20P	M5X0,8	7.1	5	13	60°	T20
	US 5025-T20P	M5X0,8	7.1	5	20	60°	T20
	US 5030-T20P	M5X0,8	7.1	6	24	60°	T20
	US 8025-T30P	M8x1,25	11.4	7	18	60°	T30

Форма Form	Обозначение Name	Размеры			Dimensions		
		a	d	h	l	b	c
	MS 3510-S3.5	M5X0.5	6,3	3,1	5,4	3,5	M3.5X0.6
	MS 4510-S5	M6X0.5	8,3	4,8	5,7	5	M4,5X0,75
	MS 5010-S6	M8X1	10	3	7	6	M5X0.5
	MS 8020-S8	M12x1	14	4,5	10,5	8	M8x1,25

Форма Form	Обозначение Name	Размеры			Dimensions	
		a	L	l	d	c
	HS 0304	M3	7	4	5.4	H2.5
	SP 0405	M4	9	6	6.8	T20

Штифты подкладной пластины - тип М

Shim pins - type M

Форма Form	Обозначение Name	Размеры					Dimensions	
		a	b	c	d	e		
	MC 3	13,5	4	4,7	5,8	3,7		
	MC 4	13	3	3,75	5,8	3,7		
	MC 5	13	4,3	5	7	5,05		
	MC 6	24	6	6	9,6	7,8		
	MC 7	18	6	6	6,25	8,4		
	MC 8	17	4,4	7,5	7,85	10		

Пружины прижима – тип D, M

Clamp springs – type D, M

Форма Form	Обозначение Name	Размеры Dimensions		
		a	b	t
	DSP 3	8	5,6	0,6
	DSP 4	13	7	0,65
	DSP 5		9	0,75

Винты прижима – тип C, D, M

Clamp screws Type C, D, M

Форма Form	Обозначение Name	Размеры Dimensions					
		a	d	h	i	b	c
	DLS 3	M4X0,7	6	8	16,8	2,5	3
	DLS 4	M5X0,8	8	8,5	21	3	3,5
	DLS 5	M6X1,0	10	12	26,5	4	4,5
	M6x16	M6X1,0	10	10	16	4	5

Прижимы – тип C, D, M

Clamps – type C, D, M

Форма Form	Обозначение Name	Размеры Dimensions				
		a	b	c	d	h
	CL 16KR/L	26,6		23,4	8	13,2
	CL 19KR/L	26,2		14	11	9
	IR-186	19	3,5	11	6,5	7,2
	IR-192	24,5	2	12	6,4	9
	WT 16	15,5	17,7	4,8	5,6	8,7
	WC 33	16,4	18	4,6	6,4	8,7
	WC 43		24			
	MW-051	17,2	16,9	10	6,5	8,2
	DLM 3	21,2	1,5	11	4,2	12,5
	DLM 4	25,8	2	14,5	5,4	13,5
	DLM 5	33,4	2	14	6,2	16,1
	DLM 6	33	2	18	6,2	19

Пластины опорные - тип Р

Shims - type P

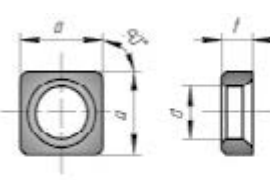
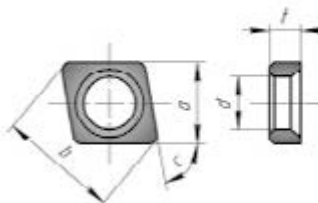
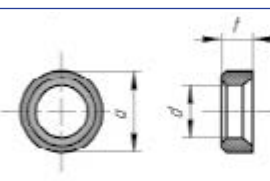
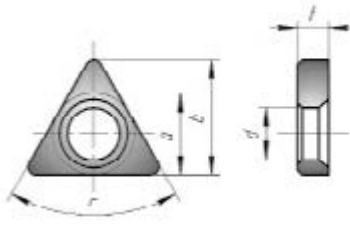
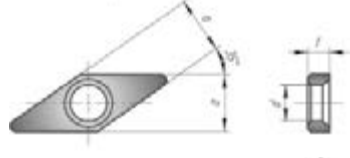
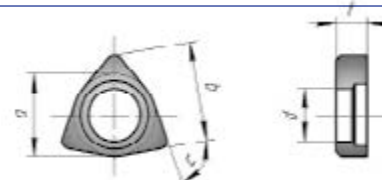
Форма Form	Обозначение Name	Размеры Dimensions				
		a	b	c	d	t
	SNU 090312	8,5		90°	5	3,18
	SNU 120312	11,4			6,6	
	SNU 150312	14,9			8,2	
	SNU 150412	14,9			8,2	4,76
	SNU 190416	18			9,8	
	SNU 250624	24,3			12,9	6,35
	CNU 090312	8,5	12,33	80°	5	3,18
	CNU 120312	11,6	16,93		6,6	
	CNU 150312	14,8	21,91		8,2	
	CNU 150412	14,8	21,91		8,2	4,76
	CNU 190416	17,95	25,85		9,8	
	CNU 250420	24,4	36,63		12,75	6,35
	CNU 250620					
	RCU 160300	13,4			6,6	3,18
	RCU 200400	17			8,2	4,76
	RCU 250600	22			9,7	6,35
	RCU 320600	28			13	
	TNU 160208	8,49	11,94	60°	5	2,7
	TNU 160308	8,63	11,95		4,9	3,18
	TNU 220312	11,7	16,75		6,6	
	TNU 270416	14,58	21,47		8,2	4,76
	TNU 330412	17,85	26,18		9,7	
	PDN 110308	8,4	17	55°	4,9	3,18
	DNU 150308	11,59	28,06		6,6	
	DNU 150408	11,59	28,06		6,6	4,76
	WNU 060308	8,7	11,7	80°	4,9	3,18
	WNU 080312	12	15,33		6,6	3,18

Пластины опорные - тип D, M

Shims - type D, M

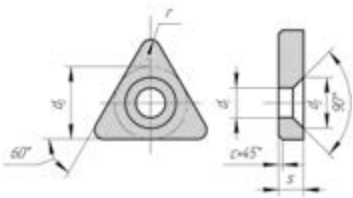

Название Name	c, мм	d0, мм	d1, мм	d2, мм	L, мм	r, мм	s, мм	Обозначение буквенно- цифровое / Code
701-1603	0,5	9,3	3,81	6,5	16,5	1,2	3,18	ONT-1603
701-1604	0,8	9,3	3,81	6,5	16,5	0,8	4,76	ONT-1604
701-2204	0,8	12,5	5,16	8,5	22	1,2	4,76	OTN-2204
701-2704	0,8	15,6	6,35	10,5	27,5	1,6	4,76	ONT-2704

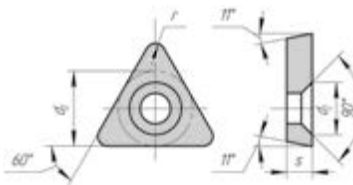

Название Name	d0, мм	d1, мм	d2, мм	L, мм	r, мм	s, мм	Обозначение буквенно- цифровое / Code
703-1603	7,5	3,81	6,5	16,5	0,8	3,18	OTP-1603
703-1604*	8,1	3,81	6,5	16,5	0,8	4,76	OTP-1604*
703-2204*	10,6	5,16	8,5	22	0,8	4,76	OTP-2204*

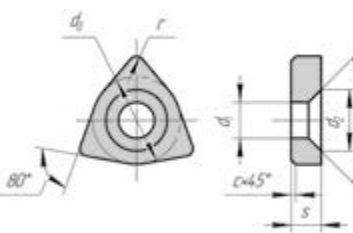

Название Name	c, мм	d0, мм	d1, мм	d2, мм	L, мм	r, мм	s, мм	Обозначение буквенно- цифровое / Code
711-0603	0,5	9,3	3,81	6,5	6,5	0,8	3,18	OWN-0603
711-0604	0,8	9,3	3,81	6,5	6,5	0,8	4,76	OWN-0604
711-0804	0,8	12,5	5,16	8,5	8,7	0,8	4,76	OWN-0804
711-1004	0,8	15,6	6,35	10,5	10,8	1,2	4,76	OWN-1004
711-1006	0,8	15,6	6,35	10,5	10,8	1,2	6,35	OWN-1006
711-1206	0,8	18,8	7,93	12,5	12,8	1,2	6,35	OWN-1206

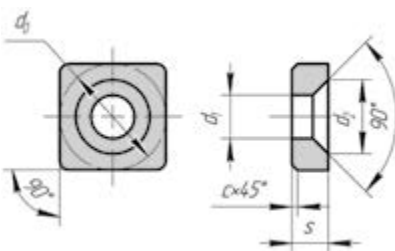

Название Name	c, мм	d0, мм	d1, мм	d2, мм	L, мм	r, мм	s, мм	Обозначение буквенно- цифровое / Code
721-0903	0,5	9,3	3,81	6,5	9,5	0,8	3,18	OSN-0903
721-1203	0,5	12,5	5,16	8,5	12,7	1,2	3,18	OSN-1203
721-1204	0,8	12,5	5,16	8,5	12,7	1,2	4,76	OSN-1204
721-1504	0,8	15,6	6,35	10,5	15,9	1,6	4,76	OSN-1504
721-1904	0,8	18,8	7,93	12,5	19	1,6	4,76	OSN-1904
721-1906	0,8	18,8	7,93	12,5	19	2,5	6,35	OSN-1906
721-2506	0,8	25,2	9,12	13,1	25,4	2,5	6,35	OSN-2506
721-2506-1	0,8	25,2	12,8	16,8	25,4	2,5	6,35	OSN-2506-1
721-3806	1	34,9	12,65	14,65	35,1	2	6,35	OSN-3806

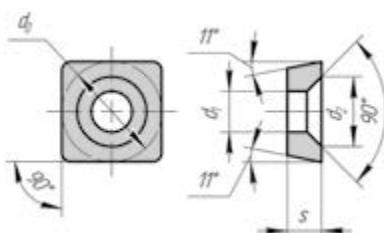

Название Name	d0, мм	d1, мм	d2, мм	L, мм	r, мм	s, мм	Обозначение буквенно- цифровое / Code
723-0903	8,1	3,81	6,5	9,5	0,8	3,18	OSP-0903
723-1203	11,3	5,16	8,5	12,7	0,8	3,18	OSP-1203
723-1204	11,3	5,16	8	12,7	0,8	4,76	OSP-1204
723-1504	13,8	6,35	10,5	15,9	1,2	4,76	OSP-1504
723-1904	17	7,93	12,5	19	0,8	4,76	OSP-1904
723-2506	22,6	9,12	13,1	25,4	2	6,35	OSP-2506

Пластины опорные - тип D, M

Shims - type D, M

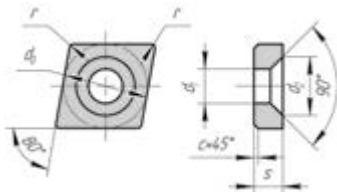

Название Name	c, мм	d0, мм	d1, мм	d2, мм	L, мм	r, мм	s, мм	Обозначение буквенно-цифровое / Code
731-0903	0,5	9,3	3,81	6,5	9,7	0,4	3,18	OCN-0903
731-1203	0,8	12,5	5,16	8,5	12,9	1,2	3,18	OCN-1203
731-1204	0,8	12,5	5,16	8,5	12,9	1,2	4,76	OCN-1204
731-1604	0,8	15,6	6,35	10,5	16,1	1,6	4,76	OCN-1604
731-1904	0,8	18,8	7,93	12,5	19,3	1,6	4,76	OCN-1904

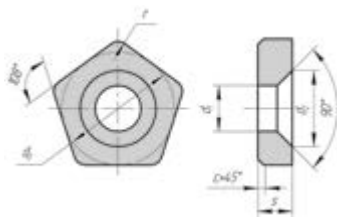

Название Name	c, мм	d0, мм	d1, мм	d2, мм	L, мм	r, мм	s, мм	Обозначение буквенно-цифровое / Code
751-1104	0,8	15,6	6,35	10,5	11,5	1,6	4,76	OPN-1104
751-1304	0,8	18,8	7,93	12,5	13,8	2	4,76	OPN-1304
751-1306	0,8	18,8	7,93	12,5	13,8	2	6,35	OPN-1306
751-1604	0,8	22	7,93	12,5	16,1	1,2	4,76	OPN-1604

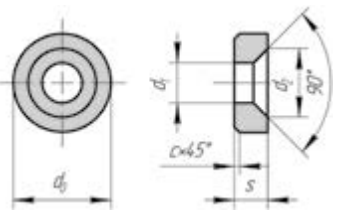

Название Name	c, мм	d, мм	d0, мм	d1, мм	d2, мм	s, мм	Обозначение буквенно-цифровое / Code
771-0903	0,5	9,525	9,3	3,81	6,5	3,18	ORN-0903
771-1203	0,5	12,7	12,5	5,16	8	3,18	ORN-1203
771-1504	0,8	15,875	15,6	6,35	9,2	4,76	ORN-1504
771-1904	0,8	19,05	18,8	6,35	9,2	4,76	ORN-1904
771-2204	0,8	22,2	22	6,35	9,2	4,76	ORN-2204
771-2506	0,8	25,4	25,2	7,93	11,1	6,35	ORN-2506

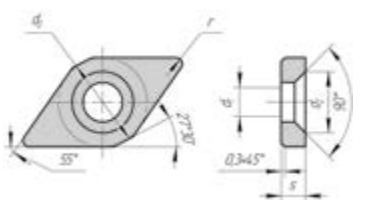

Название Name	d0, мм	d1, мм	d2, мм	L, мм	r, мм	s, мм	Обозначение буквенно-цифровое / Code
781-1103	9,3	3,8	6,5		0,8	3,18	
781-1503	11,6	5,16	8	15,5	0,8	3,18	ODN-1503

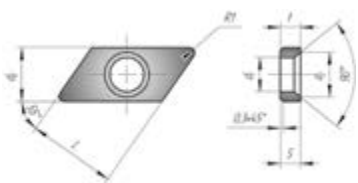

Название Name	d0, мм	d1, мм	d2, мм	L, мм	r, мм	s, мм	Обозначение буквенно-цифровое / Code
741-1704-1/2		3,81	6,5	13,8	0,8	4,76	OKN-1704-R/L
741-1904-1/2		3,81	6,5	15,8	1,2	4,76	OKN-1904-R/L
KNN 190412 R/L		3,81	6,6	14	0,8	4,76	

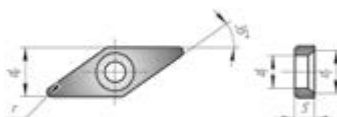

Название Name	d0, мм	d1, мм	d2, мм	L, мм	r, мм	s, мм	Обозначение буквенно-цифровое / Code
DVN 160308	8,52	3,6	6,6		0,8	3,18	

Пластины опорные - тип S

Shims - type S

Форма Form	Обозначение Name	Размеры Dimensions			
		a	b	c	d
	SSN 090304	8.4	3.18	90°	5.4
	SSN 120304	11.2	4.76		7.5
	SSN 250620	22.6	6.35		12.3
	SSN 380620	34.8			12.3
	SCN 090304	8.4	3.18	80°	5.4
	SCN 120304	11.2	4.76		7.5
	SRN 100300	8.8	3.18		5.4
	SRN 120300	10.5	3.18	5.4	
	SRN 16T3M0	14.6	3.96	7.5	
	STN 160308	8.4	3.18	60°	5.4
	SDN 110304	8.4	3.18	55°	5.4
	SVN 160304	8.3	3.18	35°	5.4

Классификация материалов

При выборе инструмента и режимов резания основным фактором является материал заготовки. Обрабатываемые материалы подразделяются на 6 групп и 24 подгруппы. Материалы одной подгруппы характеризуются сходным типом нагрузки на режущую кромку и, соответственно, вызывают одинаковый характер износа инструментального материала.

Таким образом, первый шаг – это классификация обрабатываемого материала согласно таблицы 1.

Группа	Подгруппа	Описание	Коррекция V
P	P1	Легкообрабатываемая сталь и стальное литье, низкоуглеродистые стали	1,33
	P2	Нелегированные и низколегированные стали со средним содержанием углерода ($0,25 < C < 0,55$) с прочностью до 900 МПа, твердость 160-255 HB	1,00
	P3	Сложнообрабатываемые нелегированные стали и стальное литье со средним содержанием углерода, с пределом прочности до 1000 МПа, твердость до 300 HB	0,80
	P4	Средне- и высоколегированные стали и стальное литье (с содержанием углерода $0,55 < C$), с пределом прочности до 1270 МПа, твердость до 375 HB (40 HRC)	0,60
M	M1	Ферритные нержавеющие стали	1,09
	M2	Мартенситные нержавеющие стали	1,06
	M3	Аустенитные нержавеющие стали	1,00
	M4	Ферритно-аустенитные (дуплекс), супераустенитные нержавеющие стали	0,93
K	K1	Серый чугун	1,00
	K2	Ковкий чугун	0,95
	K3	Ферритный, ферритно-перлитный высокопрочный чугун	0,90
	K4	Перлитно-ферритный, перлитный, перлитно-сорбитный высокопрочный чугун	0,85
N	N1	Алюминий и его сплавы (с низким содержанием Si), незакаленные поковки и отливки твердостью до 100 HB	1,00
	N2	Твердые сплавы алюминия, закаленные отливки (с высоким содержанием Si)	0,65
	N3	Мягкие сплавы Cu, бронзы, латуни	0,60
	N4	Труднообрабатываемые сплавы Cu	0,40
S	S1	Чистый Ti и его сплавы a, a+b a b упрочненные	1,75
	S2	Сплавы на основе Fe (INCOLOY)	1,20
	S3	Сплавы на основе Ni (INCONEL)	1,00
	S4	Сплавы на основе Co	0,75
H	H1	Высокопрочные и инструментальные стали, закаленная и отпущенная сталь твердостью 40-50 HRC	1,15
	H2	Закаленный белый чугун 350-600HV	1,10
	H3	Закаленная и отпущенная сталь твердостью 50-55HRC	1,00
	H4	Закаленные и отпущенные стали (в основном инструментальные) с твердостью более 55HRC	0,95

Classification of materials

Workpiece material is the major factor for the selection of tool and cutting mode. Workpiece materials are subdivided into 6 groups and 24 sub-groups. Materials of the same sub-group are characterized by a similar type load on the cutting edge, which results in similar pattern of tool material wear.

As can be seen from the above, the first step is the workpiece material classification according to the Table 1.

Group	Sub-group	Description	V offset
P	P1	Free-machining steel and steel casting, low-carbon steels	1,33
	P2	Non-alloy and low-alloy steels with the medium carbon content (0.25 <C<0.55), strength of up to 900 MPa and hardness of 160-255 HB	1,00
	P3	Tough-to-machine non-alloy steels and steel casting with the medium carbon content, tensile strength of up to 1000 MPa and hardness of up to 300 HB	0,80
	P4	Medium- and high-alloy steels and steel casting (with carbon content of 0.55 <C), tensile strength of up to 1270 MPa and hardness of up to 375 HB (40 HRS)	0,60
M	M1	Ferritic stainless steels	1,09
	M2	Martensitic stainless steels	1,06
	M3	Austenitic stainless steels	1,00
	M4	Ferritic-austenitic (duplex), super-austenitic stainless steels	0,93
K	K1	Grey cast-iron	1,00
	K2	Malleable cast-iron	0,95
	K3	Ferritic, ferritic-pearlitic nodular cast-iron	0,90
	K4	Pearlitic-ferritic, pearlitic, pearlitic-sorbic nodular cast-iron	0,85
N	N1	Aluminium and aluminium alloys (with the low Si content), untempered forgings and castings with hardness of up to 100 HB	1,00
	N2	Hard aluminium alloys, hard castings (with the high Si content)	0,65
	N3	Soft Cu alloys, bronze, brass	0,60
	N4	Tough-to-machine Cu alloys	0,40
S	S1	Pure Ti and titanium alloys a, a+b a b strengthened	1,75
	S2	Fe-based alloys (INCOLOY)	1,20
	S3	Ni-based alloys (INCONEL)	1,00
	S4	Co-based alloys	0,75
H	H1	High-strength and tool steels, quenched-and-tempered steel with hardness of 40-50 HRS	1,15
	H2	Hardened white cast-iron 350-600 HB	1,10
	H3	Quenched-and-tempered steel with hardness of 50-55 HRS	1,00
	H4	Quenched-and-tempered steels (generally tool steels) with hardness of over 55 HRS	0,95

Положение режущей кромки инструмента в отношении заготовки и ее геометрия определены углами, которые образуют функциональные поверхности с определенными вспомогательными плоскостями. Углы на режущей кромке инструмента определяются в двух системах координат:

- а) инструментальной
- б) рабочей

а) инструментальная (статическая) система координат, которая применяется для определения геометрии режущей кромки при конструкции, производстве и контроле, причем отдельные углы, определенные в настоящей системе, называются углами резания инструмента. К ним относятся углы, которые прямо определены стандартом ISO в соответствии с формой сменной режущей пластинки.

б) рабочая система координат – та, по которой определяется геометрия инструмента в процессе токарной обработки. Эти углы называют рабочими углами, и они зависят, прежде всего, от положения режущей пластинки в держателе инструмента. Например, у режущей пластинки SNUN задний угол $\varphi = 0^\circ$ и передний угол $\varphi = 0^\circ$, но она закреплена в резце под углом, в результате чего возникает рабочий задний угол $\varphi_0 = 6^\circ$ и рабочий передний угол $\varphi_0 = -6^\circ$. В значительной мере рабочие углы влияют и на инструментальные углы режущих пластин со стружколомом. Однако на процесс резания влияют, прежде всего, рабочие углы.

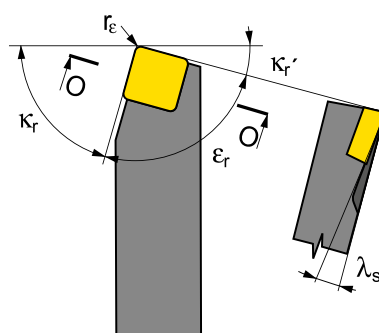
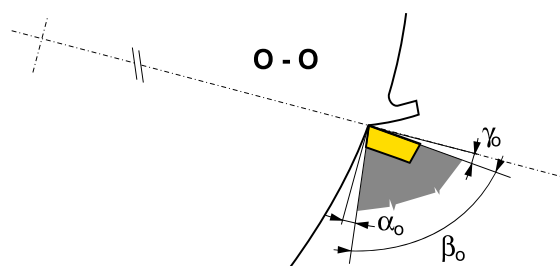

Основные углы инструмента указаны на рисунке в основной плоскости инструмента и в нормальной плоскости инструмента (плоскость расположенная перпендикулярно к режущей кромке – разрез O - O).

Рассмотрим следующие углы:

Передний угол γ_0 – имеет существенное влияние на процесс резания. От его величины зависит характер и размер пластических деформаций в процессе резания. Он определяет также величину усилий резания и уровень тепловой нагрузки на режущую кромку (лезвие). У инструментов со сменными многогранными пластинками для токарной и для фрезерной обработки его величина лежит в относительно широком диапазоне - $\varphi_0 = +25^\circ - -15^\circ$. Положительный передний угол улучшает условия образования стружки, уменьшает величину усилия резания и уровень температур в зоне резания. Отрицательный, наоборот – повышает прочность режущей кромки, но, одновременно, и усилия резания и температуру.

Задний угол α_0 оказывает влияние на величину трения между задней поверхностью пластины и обрабатываемой поверхностью. С увеличением угла α_0 трение понижается, и в результате этого уменьшается износ по задней поверхности.

Угол заострения β_0 – это угол лезвия (клина) режущей пластинки. С увеличением угла β_0 повышается прочность режущей кромки (устойчивость режущей кромки к ударам), но одновременно возрастает сопротивление резанию.

Угол наклона режущей кромки λ_s определяет зону “первого контакта” режущей кромки с заготовкой, что имеет важное значение особенно при прерывистом резании. В случае положительных величин λ_s – это место располагается ближе к вершине режущей пластинки. Отрицательный угол λ_s “отдаляет” зону первого контакта от вершины и, тем повышает устойчивость лезвия режущей части к механическим ударам. Кроме того, угол λ_s влияет и на направление отвода стружки. При отрицательном угле λ_s (вершина является самой низкой точкой режущей пластины) стружка отводится в направлении к обработанной поверхности. При положительном же угле λ_s , стружка отводится от обработанной поверхности.

Главный угол в плане режущей кромки κ_r оказывает влияние в основном на форму сечения стружки. С понижением угла (при определенной подаче f_0 и глубине резания a_p) стружка образуется более тонкой и широкой, и, наоборот – при $\kappa_r = 90^\circ$, толщина стружки равна $h = f_0 b$ и ширина стружки $b = a_p$.

Главный угол в плане вспомогательной режущей кромки κ_r' определяет вместе с радиусом закругления вершины r_1 , прежде всего, результирующую шероховатость обработанной поверхности.

Tool cutting edge position relative to workpiece and its geometry are described by angles included between functional surfaces and certain reference planes. Tool cutting edge angles are determined in two coordinate systems:

- tool coordinate system
- work coordinate system

a) tool (static) coordinate system is used for the determination of cutting edge geometry at design, manufacture and control, and particular angles set in this system are known as tool cutting angles. These include angles explicitly specified by the ISO standard depending on the replaceable cutting insert shape.

b) work coordinate system is the coordinate system, which determines the tool geometry during turning machining. These angles are known as work angles, these depend primarily on the cutting insert position in the tool holder. For example, the SNUN cutting insert has back clearance angle $\alpha = 0^\circ$ and rake angle $\gamma = 0^\circ$, but it is fastened in tool at an angle, which results in work clearance angle $\alpha_o = 6^\circ$ and work rake angle $\gamma_o = -6^\circ$.

Work angles significantly affect tool a of cutting inserts with chip-breakers. However, the cutting process is primarily affected by work angles.

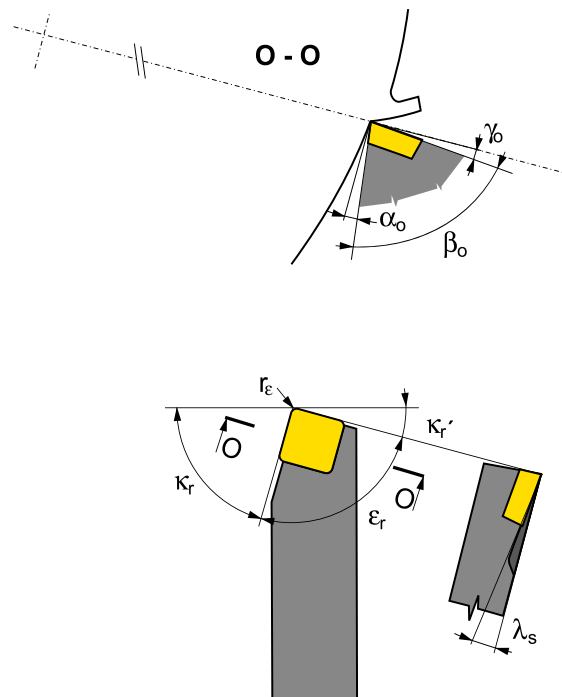

Picture shows main tool angles in the tool base plane and in the tool normal plane (plane vertical to the cutting edge: O - O section).

Let us consider the following angles:

Rake angle γ_o has a substantial influence on the cutting process. Its value determines plastic strain behavior and amount during cutting. In addition, it determines cutting force value and the cutting edge (blade) thermal load level. For turning and milling tools with the replaceable polyhedral inserts, its value has relatively wide range: $\alpha_o = +25^\circ \sim -15^\circ$.

A positive rake angle improves the chip formation conditions and reduces cutting force value and cutting area temperature level. In contrast, negative rake angle enhances cutting edge strength, but at the same time, it increases cutting force and temperature.

Back clearance angle α_o affects the value of friction between the back insert surface and the workpiece surface. Increase in the α_o angle leads to friction reduction, which results in reduction of back surface wear.

Wedge angle β_o is the angle of cutting insert tip (wedge). Increase in the β_o angle leads to enhancement of cutting edge strength (cutting edge impact resistance), but at the same time, the cutting resistance increases.

Cutting edge inclination λ_s determines the area of "first contact" of cutting edge with workpiece, which is of great importance, particularly under the intermittent cutting conditions. With positive λ_s values, this area is located closer to the cutting insert nose. Negative λ_s angle puts the first contact area away from nose and thus improves cutting tip resistance to the mechanical impacts. In addition, λ_s angle affects chip removal direction. With the negative λ_s angle (nose is the lowest point of cutting insert), chip is removed towards the machined surface. With the positive λ_s angle, chip is removed from the machined surface.

Cutting edge plan approach angle - K_r affects mainly the chip cross-section shape. Decrease in the angle (at the specific federate, fob, and cutting depth, ap) results in thinner and wider chips, and vice versa – at $K_r = 90^\circ$, chip thickness $h = fob$ and chip width $b = ap$.

Trailing edge plan approach angle K_r , along with the nose radius, r_ϵ , determines primarily resulting machined surface roughness.

Выбор сечения резца, в большинстве случаев, определяется возможностями станка, однако для случая, когда есть возможность выбора, приводим следующую номограмму. С ее помощью возможно определить оптимальное сечение державки, исходя из режимов резания: величин подачи, глубины резания и вылета инструмента.

In most cases, the selection of tool section depends on machine capacity, however, for the case of choice availability, following nomographic chart is provided. It enables determination of the optimum tool holder cross-section based on the cutting conditions: feed-rate value, cutting depth and holder overhang.

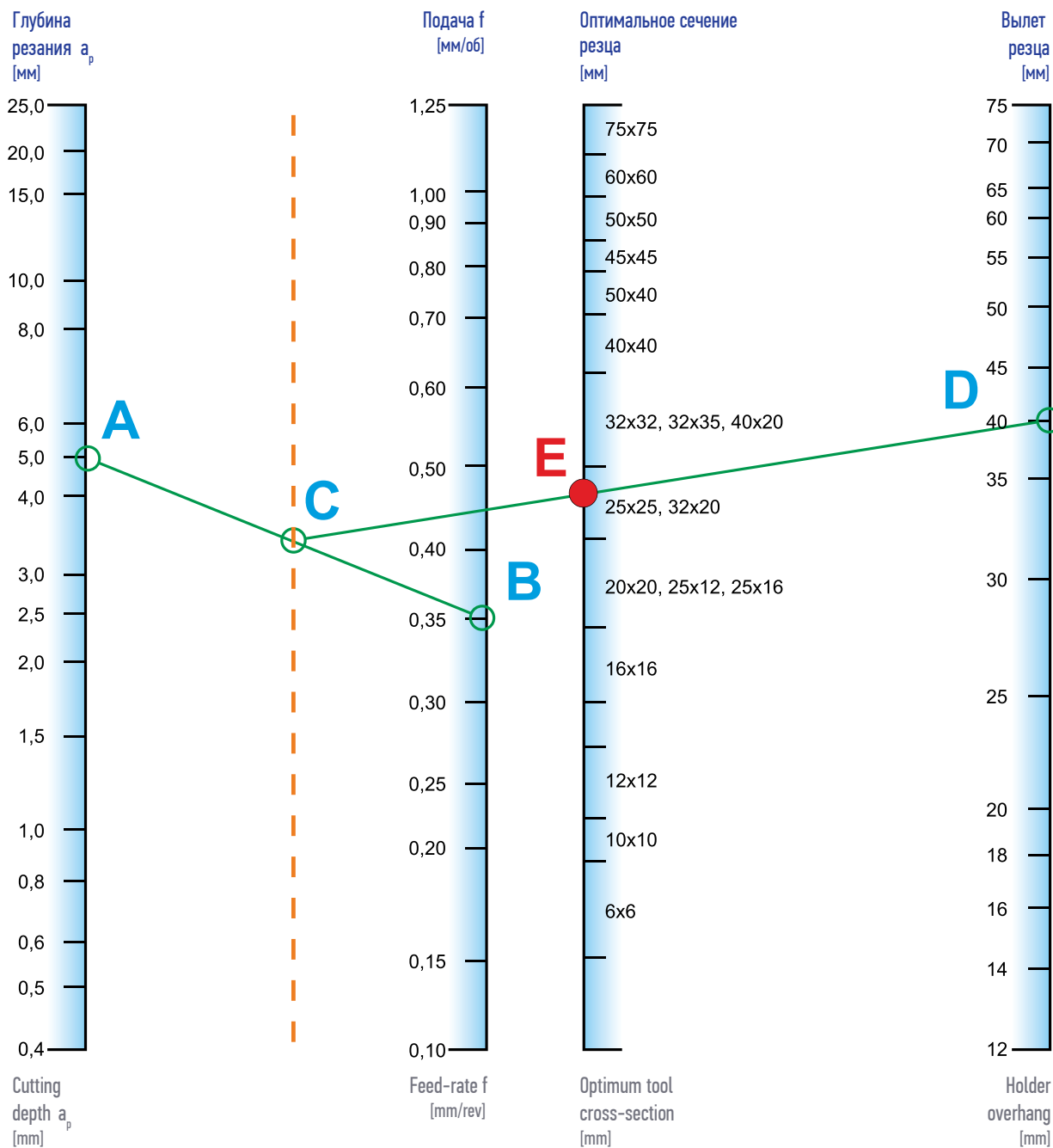

Сначала соединим выбранную глубину резания a_p (точка А) с выбранной (или максимально применимой) подачей f (точка В). От точки пересечения пунктирной линии и прямой А - В (точка С), проведем отрезок к точке, обозначающей величину вылета резца (точка D). На второй оси справа (сечение державки) получаем значение оптимального сечения резца, исходя из выбранных условий резания (точка E).

First, connect the chosen cutting depth a_p (point A) with the chosen (or maximum usable) feed-rate f (point B). Draw an intercept from intersection of dotted line and straight A - B line (point C) to the point representing holder overhang value (point D). On the second axis on the right (tool holder cross-section), there will be the value of optimum tool cross-section based on the chosen cutting conditions (point E).

Выбор основной формы и размера режущей пластины.
Selection of main form and size of cutting insert.

Приоритет выбора Selection priority		Основная форма СМП Main form CMI		Размер С Size C		Максимальная допустимая глубина резания, в зависимости от длины режущей кромки L_{max} [мм] Maximum allowable depth of cut, depending on length of the cutting edge L_{max} [mm]	
↑ Повышается универсальность применения пластин. Inserts use flexibility is increased	↓ Повышается устойчивость к пластической деформации и прерывистому резанию. Resistance to plastic deformation and interrupted cutting is increased		V	11	0,25L	2,8	
				16		4,2	
			D	07	0,25L	2,0	
				11		2,9	
				15		3,9	
			K	16	0,25L	4,7	
				19		4,7	
			T	11	0,33L	3,6	
				16		5,5	
				22		7,3	
				27		9,1	
			W	06	0,50L	3,3	
				08		4,4	
			C	06	0,66L	4,2	
				09		6,4	
				12		8,5	
				16		10,6	
				19		12,7	
			S	25	0,66L	16,5	
				09		6,3	
12	8,4						
15	10,4						
19	12,6						
	R	25	0,40D	16,8			
		38		25,0			
		06		2,4			
		08		3,2			
		10		4,0			
		12		4,8			
		15		6,0			
		16		6,4			
		19		7,6			
		20		8,0			
25	10,0						
32	12,8						

Выбор радиуса при вершине пластины.

Радиус при вершине пластины – r_n (последняя двузначная цифра в коде ISO ее обозначения) должен быть, по возможности, наибольшим. Его размер, вместе с углом при вершине СМП, определяется формой пластины, и оказывает влияние на устойчивость режущей кромки к пластической деформации вершины: чем больший радиус закругления r_n , тем больше устойчивость к пластической деформации и к разрушению вершины пластины в результате превышения предела теплостойкости материала СМП. Большая величина r_n позволяет применение более высоких подач, но одновременно требует большей жесткости системы “станок – инструмент – заготовка”. В случае обработки нежестких заготовок СМП с большим радиусом пластины при вершине, возрастает вероятность возникновения вибраций. Для первого выбора радиуса СМП можно применить номограмму:

Selection of insert nose radius.

Insert nose radius, r_n (the last two-digit number of its ISO code designation) must be as large as possible. This dimension, along with cutting indexable insert nose angle, depends on the insert shape and affects cutting edge resistance to the nose plastic strain: the greater nose radius r_n , the higher resistance to the plastic strain and insert nose destruction due to overrange of limit of the thermal stability of cutting indexable insert material. The greater r_n value allows usage of higher feed-rates, but at the same time, it requires higher rigidity of “machine – tool – workpiece” system. In the case of non-rigid workpiece machining with the use of cutting indexable insert having large insert nose radius, probability of vibration occurrence increases. Following nomographic chart could be used for the first selection of the cutting indexable insert radius:

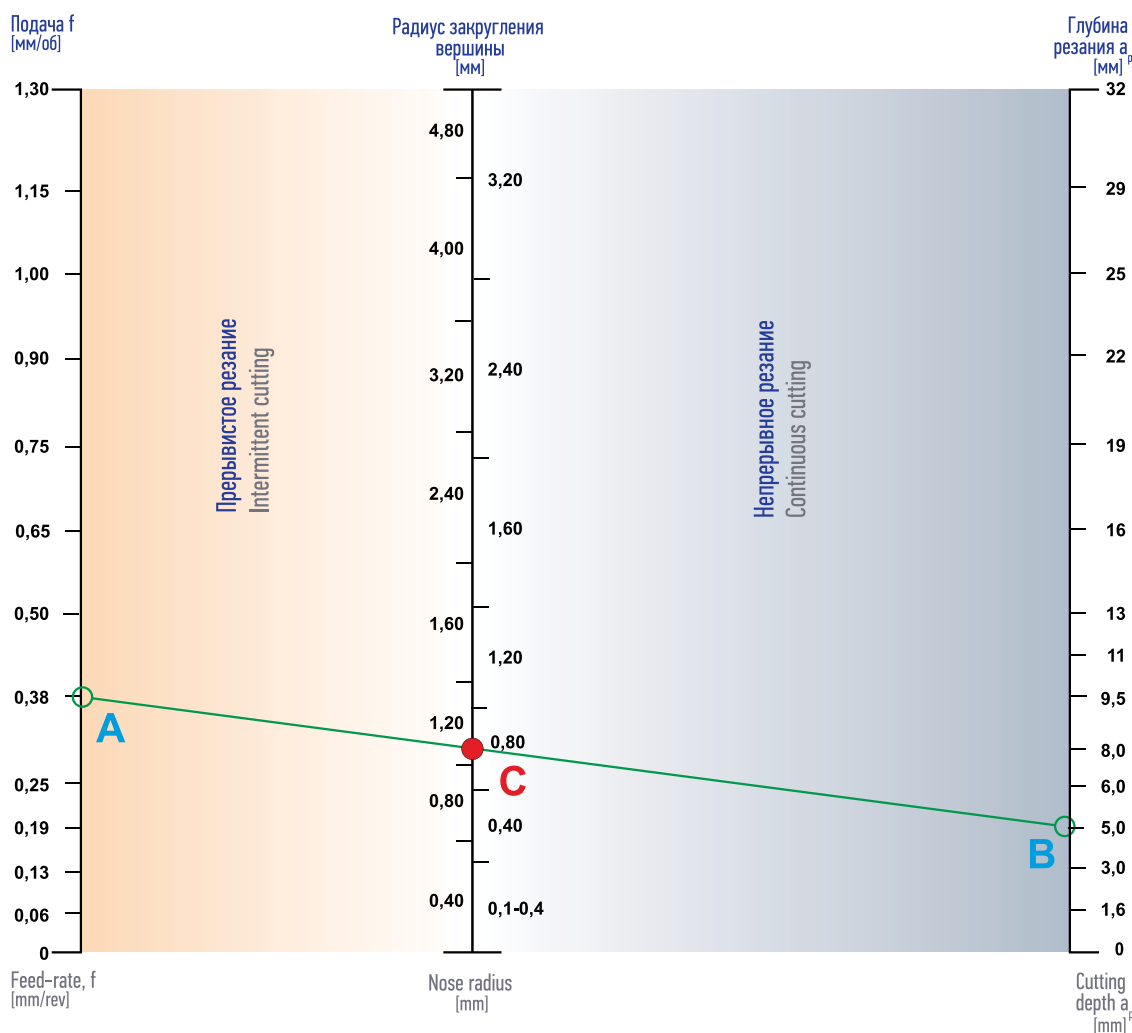

Пример применения номограммы:

Выбрав подачу (или максимальную подачу) (точка A) и глубину резания a_p (точка B), при которых будет данная СМП работать, получаем значение радиуса при вершине пластины для условий прерывистого/непрерывного резания (точка C), как результат пересечения отрезка A-B и средней вертикальной оси номограммы.

By selecting the feed-rate (or maximum feed-rate) (point A) and cutting depth a_p (point B) for operation of particular cutting indexable insert, we will obtain value of insert nose radius for intermittent / continuous cutting conditions (point C) in the intersection point of the A-B intercept and middle vertical axis of nomographic chart.

Каждый стружколом работает в определенном диапазоне режимов резания. Все стружколомающие геометрии создаются таким образом, чтобы иметь пересечение зоны своей функциональной области применения с зоной другой стружколомающей геометрии, близкой по назначению. Таким образом, полностью покрывается одна общая зона — зона «наиболее часто используемых» режимов обработки: сочетаний определенных величин глубины резания и подачи (см. схему).

Each chip-breaker operates within the specific range of the cutting conditions. Each of chip-breaking geometries is designed so that its functional effective range zone overlaps with such zone of other chip-breaking geometry of similar purpose. As can be seen from the above, completely overlapped is one common zone, namely zone of the “most often used” machining conditions: combinations of specific values of cutting depth and feed-rate (see chart).

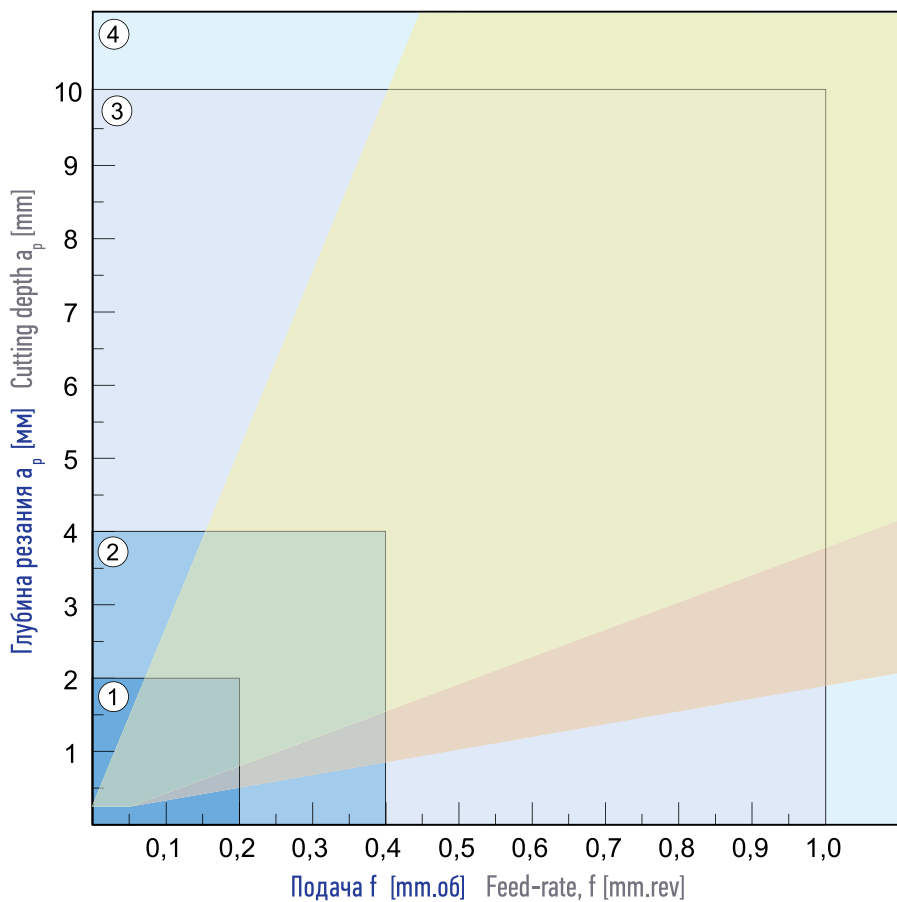

- 1** Тонкое (окончательное) и чистовое точение

подача $f = 0,05 \text{ мм} \div 0,2 \text{ мм/об}$
 глубина резания $a_p = 0,05 \text{ мм} \div 2 \text{ мм}$

Fine (final) turning and finishing

feed-rate $f = 0.05 \text{ mm} \div 0.2 \text{ mm/rev}$
 cutting depth $a_p = 0.05 \text{ mm} \div 2 \text{ mm}$
- 2** Полушеровое точение

подача $f = 0,2 \text{ мм} \div 0,4 \text{ мм/об}$
 глубина резания $a_p = 2 \text{ мм} \div 4 \text{ мм}$

Semi-rough turning

feed-rate $f = 0.2 \text{ mm} \div 0.4 \text{ mm/rev}$
 cutting depth $a_p = 2 \text{ mm} \div 4 \text{ mm}$
- 3** Черновое точение

подача $f = 0,4 \text{ мм} \div 1,0 \text{ мм/об}$
 глубина резания $a_p = 4 \text{ мм} \div 10 \text{ мм}$

Rough turning

feed-rate $f = 0.4 \text{ mm} \div 1.0 \text{ mm/rev}$
 cutting depth $a_p = 4 \text{ mm} \div 10 \text{ mm}$
- 4** Тяжелое обдирочное точение

подача $f = > 1,0 \text{ мм/об}$
 глубина резания $a_p = > 10 \text{ мм}$

Heavy rough turning

feed-rate $f = > 1.0 \text{ mm/rev}$
 cutting depth $a_p = > 10 \text{ mm}$

Величина	Формула для расчёта	Единица	Примечание
Число оборотов	$n = \frac{v_c \cdot 1000}{D \cdot \pi}$	[об/мин]	<p>n число оборотов [об/мин] D диаметр (инструмента или заготовки) [мм] v_c скорость резания [м/мин] f_{ot} подача (за один оборот) [мм/об] f_{min} минутная подача (скорость подачи) [мм/мин]</p>
Скорость резания	$v_c = \frac{\pi \cdot D \cdot n}{1000}$	[м/мин]	
Подача на один оборот	$f_{ot} = \frac{f_{min}}{n}$	[мм/об]	
Минутная подача (скорость подачи)	$f_{min} = v_f = f_{ot} \cdot n$	[м/мин]	
Теоретическое значение максимальной микронеровности поверхности	$R_{max} = \frac{125 \cdot f_{ot}^2}{r_\xi}$	[мкм]	<p>R_{max} теоретическое значение максимальной неровности поверхности [мм] R_a средняя шероховатость обработанной поверхности [мм] f_{ot} подача за один оборот [мм/об] r_e радиус закругления вершины инструмента [мм]</p>
Средняя шероховатость обработанной поверхности	$R_a = \frac{43,9 \cdot f_{ot}^{1,88}}{r_\xi^{0,97}}$	[мкм]	
Сечение (площадь) стружки	$A = f_{ot} \cdot a_p$	[мм ²]	<p>A сечение стружки [мм²] f_{ot} подача за один оборот [мм/об] a_p глубина резания [мм] κ_r угол в плане главной режущей кромки [°] h толщина стружки [мм] v_c скорость резания [м/мин] f_{min} минутная подача (скорость подачи) [мм/мин] Q снятый объем материала за единицу времени [см³/мин]</p>
Толщина стружки (для СМП без стружколома)	$h = f_{ot} \cdot \sin \kappa_r$	[мм]	
Толщина стружки (для круглых СМП)	$h = f_{ot} \cdot \sqrt{\frac{a_p}{D}}$	[мм]	
Снятый объем материала	$Q = a_p \cdot f_{ot} \cdot v_c$	[см ³ .мин]	
Потребляемая мощность	$P_c = \frac{a_p \cdot f_{ot}^{1-c} \cdot k_{cl} \cdot v_c \cdot \kappa_r}{6 \cdot 10^4 \cdot \eta}$	[кВт]	<p>P_c потребляемая мощность [кВт] a_p глубина резания [мм] f_{ot} подача [мм/об] c постоянная K_{η} [1] k_c удельное сопротивление резанию [МПа] k_g коэффициент, включающий влияние угла γ_0 [1] η эффективность станка (как правило $\eta = 0,75$) [1] x коэффициент, учитывающий влияние обрабатываемого материала [1]</p>
Приблизительная потребляемая мощность	$P_c = \frac{a_p \cdot f_{ot} \cdot v_c}{x}$	[кВт]	

материал	сталь	чугун	Al
коэффициент	20	25	100

Magnitude	Formula for calculating	Unit	Notes
Rotary speed	$n = \frac{v_c \cdot 1000}{D \cdot \pi}$	[Rpm]	n number of rotations [Rpm] D diameter [mm]
Cutting speed	$v_c = \frac{\pi \cdot D \cdot n}{1000}$	[m/min]	v _c cutting speed [m/min] f _{ot} feed (per one rotation) [mm/r] f _{min} minute feed (speed of feed) [mm/min]
One rotation feed	$f_{ot} = \frac{f_{min}}{n}$	[mm/r]	
Minute feed (feed rate)	$f_{min} = v_f = f_{ot} \cdot n$	[m/min]	
Theoretical value of maximum surface microasperity	$R_{max} = \frac{125 \cdot f_{ot}^2}{r_\xi}$	[mym]	R _{max} theoretical value of maximum surface variance [mm] R _a average roughness of machined surface [mm]
Average roughness of machined surface	$R_a = \frac{43,9 \cdot f_{ot}^{1,88}}{r_\xi^{0,97}}$	[mym]	f _{ot} feed per one rotation [mm/r] r _c radius of rounding of tool top [mm]
Chip scrap area	$A = f_{ot} \cdot a_p$	[mm ²]	A area of chip [mm ²] f _{ot} feed per one rotation [mm/r] a _p depth of cut [mm] κ _r entering angle of mail cutting edge [°]
Chip thickness (for polygonal inserts without chip breaker)	$h = f_{ot} \cdot \sin \kappa_r$	[mm]	h chip thickness [mm] v _c speed of cutting [m/min]
Chip thickness (for round polygonal inserts)	$h = f_{ot} \cdot \sqrt{\frac{a_p}{D}}$	[mm]	f _{min} minute feed (speed of feed) [mm/min] Q removed volume of material for unit of time [cm ³ /min]
Removed volume of material	$Q = a_p \cdot f_{ot} \cdot v_c$	[cm ³ /min]	
Working power	$P_c = \frac{a_p \cdot f_{ot}^{1-c} \cdot k_{cl} \cdot v_c \cdot \kappa_r}{6 \cdot 10^4 \cdot \eta}$	[kW]	P _c working power [kW] a _p depth of cutting [mm] f _{ot} feed [mm/r] c constant K _v [1] k _c unit resistance to cut [MPa] k _a rate with angle effect γ _a [1] η machine efficiency (usually η = 0,75) [1] x rate considers influence of machined material [1]
Approximate working power	$P_c = \frac{a_p \cdot f_{ot} \cdot v_c}{x}$	[kW]	

material	steel	cast iron	Al
rate	20	25	100

Предел прочности [МПа] Breaking point (MPa)	ТВЕРДОСТЬ HARDNESS				Предел прочности [МПа] Breaking point (MPa)	ТВЕРДОСТЬ HARDNESS			
	BRINELL	VICKERS	ROCKWELL	ROCKWELL		BRINELL	VICKERS	ROCKWELL	ROCKWELL
Rm	HB/HRC	HV	HRB	HRC	Rm	HB/HRC	HV	HRB	HRC
285	86	90	52,4	-	1190	352	370	-	37,7
320	95	100	56,2	-	1220	361	380	-	38,8
350	105	110	62,3	-	1255	371	390	-	39,8
385	114	120	66,7	-	1290	380	400	-	40,8
415	124	130	71,2	-	1320	390	410	-	41,8
450	133	140	75	-	1350	399	420	-	42,7
480	143	150	78,7	-	1385	409	430	-	43,6
510	152	160	81,7	-	1420	418	440	-	44,5
545	162	170	85,8	-	1455	428	450	-	45,3
575	171	180	87,1	-	1485	437	460	-	46,1
610	181	190	89,5	-	1520	447	470	-	46,9
640	190	200	91,5	-	1555	456	480	-	47,7
675	199	210	93,5	-	1595	466	490	-	48,4
705	209	220	95	-	1630	475	500	-	49,1
740	219	230	96,7	-	1665	485	510	-	49,8
770	228	240	98,1	-	1700	494	520	-	50,5
800	238	250	99,5	-	1740	504	530	-	51,1
820	242	255	-	23,1	1775	513	540	-	51,7
850	252	265	-	24,8	1810	523	550	-	52,3
880	261	275	-	26,4	1845	532	560	-	53
900	266	280	-	27,1	1880	542	570	-	53,6
930	276	290	-	28,5	1920	551	580	-	54,1
950	280	295	-	29,2	1955	561	590	-	54,7
995	295	310	-	31	1995	570	600	-	55,2
1030	304	320	-	32,2	2030	580	610	-	55,7
1060	314	330	-	33,3	2070	589	620	-	56,3
1095	323	340	-	34,4	2105	599	630	-	56,8
1125	333	350	-	35,5	2145	608	640	-	57,3
1155	342	360	-	36,6	2180	618	650	-	57,8



Система обозначения

Symbol system



Сверла серии BDS

Drills - BDS series

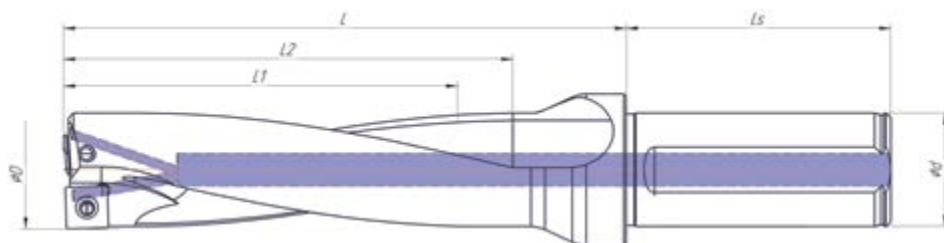

Обозначение Name	Размеры Dimensions									Пластина Insert	Винт Screw	Ключ Key
	D	d	Ls	3D			4D					
				L1	L2	L	L1	L2	L			
BDS 18025-*D	18,0	25	56	54	57	82	72	75	100	SP...060204	US 2205	T07
BDS 18525-*D	18,5	25	56	56	59	84	74	77	102	SP...060204	US 2205	T07
BDS 19025-*D	19,0	25	56	57	60	85	76	79	104	SP...060204	US 2205	T07
BDS 19525-*D	19,5	25	56	59	62	87	78	81	106	SP...060204	US 2205	T07
BDS 20025-*D	20,0	25	56	60	63	88	80	83	108	SP...060204	US 2205	T07
BDS 20525-*D	20,5	25	56	62	65	90	82	85	110	SP...060204	US 2205	T07
BDS 21025-*D	21,0	25	56	63	66	91	84	87	112	SP...060204	US 2205	T07
BDS 21525-*D	21,5	25	56	65	68	93	86	89	114	SP...060204	US 2205	T07
BDS 22032-*D	22,0	25	56	66	69	94	88	91	121	SP...07T308	US 2506	T07
BDS 22532-*D	22,5	25	56	68	71	96	90	93	123	SP...07T308	US 2506	T07
BDS 23032-*D	23,0	32	60	69	72	102	92	95	125	SP...07T308	US 2506	T07
BDS 23532-*D	23,5	32	60	71	74	104	94	97	127	SP...07T308	US 2506	T07
BDS 24032-*D	24,0	32	60	72	75	105	96	99	129	SP...07T308	US 2506	T07
BDS 24532-*D	24,5	32	60	74	77	107	98	101	131	SP...07T308	US 2506	T07
BDS 25032-*D	25,0	32	60	75	78	108	100	103	133	SP...07T308	US 2506	T07
BDS 25532-*D	25,5	32	60	77	80	110	102	105	135	SP...07T308	US 2506	T07
BDS 26032-*D	26,0	32	60	78	81	111	104	107	137	SP...07T308	US 2506	T07
BDS 26532-*D	26,5	32	60	80	83	113	106	109	139	SP...07T308	US 2506	T07
BDS 27032-*D	27,0	32	60	81	84	114	108	111	141	SP...07T308	US 2506	T07
BDS 27032-*D	27,5	32	60	83	86	116	110	113	143	SP...07T308	US 2506	T07
BDS 28032-*D	28,0	32	60	84	87	117	112	115	145	SP...090408	US 3510	T15
BDS 28532-*D	28,5	32	60	86	89	119	114	117	147	SP...090408	US 3510	T15
BDS 29032-*D	29,0	32	60	87	90	120	116	120	150	SP...090408	US 3510	T15
BDS 29532-*D	29,5	32	60	89	93	123	118	123	153	SP...090408	US 3510	T15
BDS 30032-*D	30,0	32	60	90	95	125	120	125	155	SP...090408	US 3510	T15
BDS 31032-*D	31,0	32	60	93	98	128	124	129	159	SP...090408	US 3510	T15
BDS 32032-*D	32,0	32	60	96	101	131	128	133	163	SP...090408	US 3510	T15
BDS 33032-*D	33,0	32	60	99	104	134	132	137	167	SP...090408	US 3510	T15
BDS 34040-*D	34,0	40	70	102	107	142	136	141	176	SP...090408	US 3510	T15
BDS 35040-*D	35,0	40	70	105	110	145	140	145	180	SP...090408	US 3510	T15
BDS 36040-*D	36,0	40	70	108	113	148	144	149	184	SP...090408	US 3510	T15
BDS 37040-*D	37,0	40	70	111	116	151	148	153	188	SP...090408	US 3510	T15
BDS 38040-*D	38,0	40	70	114	119	154	152	157	192	SP...090408	US 3510	T15
BDS 39040-*D	39,0	40	70	117	122	157	156	161	196	SP...090408	US 3510	T15
BDS 40040-*D	40,0	40	70	120	125	160	160	165	200	SP...090408	US 3510	T15
BDS 41040-*D	41,0	40	70	123	128	163	164	169	204	SP...090408	US 3510	T15
BDS 42040-*D	42,0	40	70	126	131	166	168	173	208	SP...140512	US 5012	T20

Сверла серии BDW

Drills - BDW series

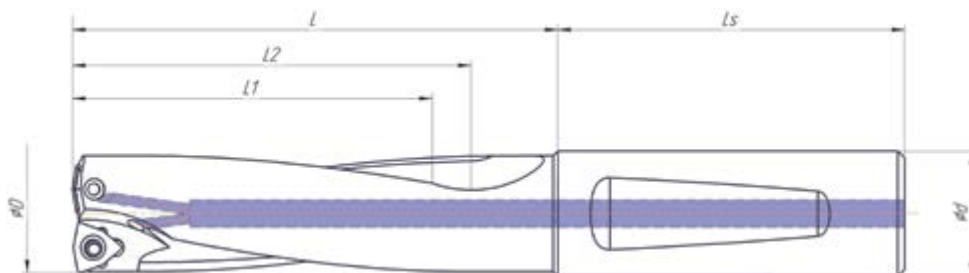

Обозначение Name	Размеры Dimensions															Пластина Insert	Винт Screw	Ключ Key
	D	d	Ls	2D			3D			4D			5D					
				L1	L2	L	L1	L2	L	L1	L2	L	L1	L2	L			
BDW 18025-*D	18,0	25	56	36	39	64	54	57	82	72	75	100	90	93	118	WC..030204	US 2205	T07
BDW 18525-*D	18,5	25	56	37	40	65	56	59	84	74	77	102	93	96	121	WC..030204	US 2205	T07
BDW 19025-*D	19,0	25	56	38	41	66	57	60	85	76	79	104	95	98	123	WC..030204	US 2205	T07
BDW 19525-*D	19,5	25	56	39	42	67	59	62	87	78	81	106	98	101	126	WC..030204	US 2205	T07
BDW 20025-*D	20,0	25	56	40	43	68	60	63	88	80	83	108	100	103	128	WC..030204	US 2205	T07
BDW 20525-*D	20,5	25	56	41	44	69	62	65	90	82	85	110	103	106	131	WC..040204	US2506	T07
BDW 21025-*D	21,0	25	56	42	45	70	63	66	91	84	87	112	105	108	133	WC..040204	US2506	T07
BDW 21525-*D	21,5	25	56	43	46	71	65	68	93	86	89	114	108	111	136	WC..040204	US2506	T07
BDW 22032-*D	22,0	25	56	44	47	72	66	69	94	88	91	121	110	113	143	WC..040204	US2506	T07
BDW 22532-*D	22,5	25	56	45	48	73	68	71	96	90	93	123	113	116	146	WC..040204	US2506	T07
BDW 23032-*D	23,0	25	56	46	49	74	69	72	97	92	95	125	115	118	148	WC..040204	US2506	T07
BDW 23532-*D	23,5	25	56	47	50	75	71	74	99	94	97	127	118	121	151	WC..040204	US2506	T07
BDW 24032-*D	24,0	25	56	48	51	76	72	75	100	96	99	129	120	123	153	WC..040204	US2506	T07
BDW 24532-*D	24,5	25	56	49	52	77	74	77	102	98	101	131	123	126	156	WC..040204	US2506	T07
BDW 25032-*D	25,0	25	56	50	53	78	75	78	103	100	103	133	125	128	158	WC..040204	US2506	T07
BDW 25532-*D	25,5	32	60	51	54	84	77	80	110	102	105	135	128	131	161	WC..050308	US3007	T09
BDW 26032-*D	26,0	32	60	52	55	85	78	81	111	104	107	137	130	133	163	WC..050308	US3007	T09
BDW 26532-*D	26,5	32	60	53	56	86	80	83	113	106	109	139	133	136	166	WC..050308	US3007	T09
BDW 27032-*D	27,0	32	60	54	57	87	81	84	114	108	111	141	135	138	168	WC..050308	US3007	T09
BDW 27532-*D	27,5	32	60	55	58	88	83	86	116	110	113	143	138	141	171	WC..050308	US3007	T09
BDW 28032-*D	28,0	32	60	56	59	89	84	87	117	112	115	145	140	143	173	WC..050308	US3007	T09
BDW 28532-*D	28,5	32	60	57	60	90	86	89	119	114	117	147	143	146	176	WC..050308	US3007	T09
BDW 29032-*D	29,0	32	60	58	61	91	87	90	120	116	120	150	145	149	179	WC..050308	US3007	T09
BDW 29532-*D	29,5	32	60	59	62	92	89	92	122	118	123	153	148	153	183	WC..050308	US3007	T09
BDW 30032-*D	30,0	32	60	60	63	93	90	93	123	120	125	155	150	155	185	WC..050308	US3007	T09
BDW 31032-*D	31,0	32	60	62	65	95	93	96	126	124	129	159	155	160	190	WC..06T308	US 3510	T15
BDW 32032-*D	32,0	32	60	64	67	97	96	99	129	128	133	163	160	165	195	WC..06T308	US 3510	T15
BDW 33032-*D	33,0	32	60	66	69	99	99	102	132	132	137	167	165	170	200	WC..06T308	US 3510	T15
BDW 34040-*D	34,0	32	60	68	71	101	102	105	135	136	141	176	170	175	210	WC..06T308	US 3510	T15
BDW 35040-*D	35,0	32	60	70	73	103	105	108	138	140	145	180	175	180	215	WC..06T308	US 3510	T15
BDW 36040-*D	36,0	32	60	72	75	105	108	111	141	144	149	184	180	185	220	WC..06T308	US 3510	T15
BDW 37040-*D	37,0	32	60	74	77	107	111	114	144	148	153	188	185	190	225	WC..06T308	US 3510	T15
BDW 38040-*D	38,0	32	60	76	79	109	114	117	147	152	157	192	190	195	230	WC..06T308	US 3510	T15
BDW 39040-*D	39,0	32	60	78	81	111	117	120	150	156	161	196	195	200	235	WC..06T308	US 3510	T15
BDW 40040-*D	40,0	32	60	80	83	113	120	123	153	160	165	200	200	205	240	WC..06T308	US 3510	T15
BDW 41040-*D	41,0	32	60	82	85	115	123	126	156	164	169	204	205	210	245	WC..06T308	US 3510	T15
BDW 42040-*D	42,0	40	70	84	87	122	126	129	164	168	173	208	210	215	250	WC..080408	US 4011	T15
BDW 43040-*D	43,0	40	70	86	89	124	129	132	167	172	177	212	215	220	255	WC..080408	US 4011	T15
BDW 44040-*D	44,0	40	70	88	91	126	132	135	170	176	181	216	220	225	260	WC..080408	US 4011	T15
BDW 45040-*D	45,0	40	70	90	93	128	135	138	173	180	185	220	225	230	265	WC..080408	US 4011	T15
BDW 46040-*D	46,0	40	70	92	95	130	138	141	176	184	189	224	230	235	270	WC..080408	US 4011	T15
BDW 47040-*D	47,0	40	70	94	97	132	141	144	179	188	193	228	235	240	275	WC..080408	US 4011	T15
BDW 48040-*D	48,0	40	70	96	99	134	144	147	182	192	197	232	240	245	280	WC..080408	US 4011	T15
BDW 49040-*D	49,0	40	70	98	101	136	147	150	185	196	201	236	245	250	285	WC..080408	US 4011	T15
BDW 50040-*D	50,0	40	70	100	103	138	150	153	188	200	205	240	250	255	290	WC..080408	US 4011	T15
BDW 51040-*D	51,0	40	70	102	105	140	153	156	191	204	209	244	255	260	295	WC..080408	US 4011	T15
BDW 52040-*D	52,0	40	70	104	107	142	156	159	194	208	213	248	260	265	300	WC..080408	US 4011	T15
BDW 53040-*D	53,0	40	70	106	109	144	159	162	197	212	217	252	265	270	305	WC..080408	US 4011	T15
BDW 54040-*D	54,0	40	70	108	111	146	162	165	200	216	221	256	270	275	310	WC..080408	US 4011	T15
BDW 55040-*D	55,0	40	70	110	113	148	165	168	203	220	225	260	275	280	315	WC..080408	US 4011	T15
BDW 56040-*D	56,0	40	70	112	115	150	168	171	206	224	229	264	280	285	320	WC..080408	US 4011	T15
BDW 57040-*D	57,0	40	70	114	117	152	171	174	209	228	233	268	285	290	325	WC..080408	US 4011	T15
BDW 58040-*D	58,0	40	70	116	119	154	174	177	212	232	237	272	290	295	330	WC..080408	US 4011	T15

Фрезы | Mills



Система обозначения

Symbol system

B	F	A	080	088	Z09	06		027	050	SV APKX16	
↑	↑	↑	↑	↑	↑	↑	↑	↑	↑	↑	↑
ДЗС DSTP	F-фреза F-mill	Тип крепления: A – на оправку E – цилиндрический хвостовик R – резьба W – weldon X – специальное Mountins: A – arbor E – cylindrical shaun R – thread W – weldon X – special	D – 3 знака D – 3 digits	угол в плане - 3 знака entry angle - 3 digits	Z – кол-во зубьев Z - number of teeth	Задний угол зачистной фаски Back angle	наличие СОЖ N – отсутствует Coolant N – no	d посадочный – 3 знака d – 3 digits	L общая – 3 знака L total – 3 digits	Обозначение пластины insert code	Дополни- тельное обозначение Additional marks

088SN12

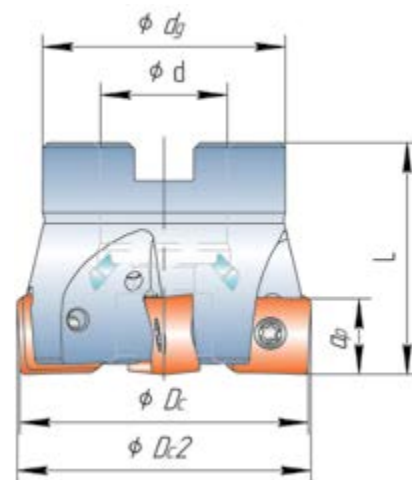

Наименование Name	Кол-во зубьев Number of teeth	Габариты Dimensions					Вес, kg Weight, kg	Тип оправки Mounting	ar, mm	Режущая пластина* Cutting insert*
		$\square D_c$	$\square D_c/2$	$\square d$	$\square d_g$	L				
BFA-050088-Z05-06-022040	5	50	50,9	22	42	40	0,400	A	10,5	SNHU 1206
BFA-050088-Z06-06-022040	6	63	63,9	22	48	40	0,500	A	10,5	SNHU 1206
BFA-063088-Z07-06-027050	7	80	80,9	27	60	50	1,000	A	10,5	SNHU 1206
BFA-080088-Z09-06-027050	9	80	80,9	27	60	50	1,000	A	10,5	SNHU 1206
BFA-100088-Z08-06-032050	8	100	100,9	32	73	50	1,600	B	10,5	SNHU 1206
BFA-100088-Z11-06-032050	11	100	100,9	32	73	50	1,500	B	10,5	SNHU 1206
BFA-125088-Z10-06-040063	10	125	125,9	40	90	63	3,100	B	10,5	SNHU 1206
BFA-125088-Z14-06-040063	14	125	125,9	40	90	63	3,000	B	10,5	SNHU 1206
BFA-160088-Z12-06-N040063	12	160	160,9	40	110	63	3,700	C	10,5	SNHU 1206
BFA-160088-Z18-06-N040063	18	160	160,9	40	110	63	3,500	C	10,5	SNHU 1206
BFA-200088-Z14-06-N060063	12	200	200,9	60	172	63	6,300	C	10,5	SNHU 1206
BFA-200088-Z22-06-N060063	22	200	200,9	60	172	63	6,100	C	10,5	SNHU 1206

* **имеем возможность производства фрез под аналогичные пластины любых марок.**

* **we can design and produce mills for any insert type and brand.**



090AN10

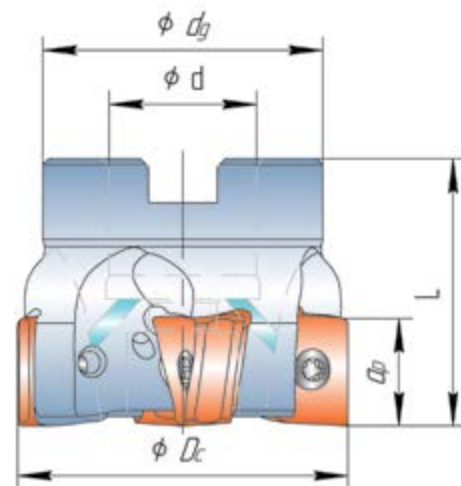

Наименование Name	Кол-во зубьев Number of teeth	Габариты Dimensions					Вес, kg Weight, kg	Тип оправки Mounting	ar, mm	Режущая пластина* Cutting insert*
		ϕD_c	ϕD_c2	ϕd	ϕd_g	L				
BFW-014090-Z01-06-016090	1	14	16	-	90	23	0,118	-	9,0	АНХ1004
BFW-016090-Z01-06-016090	1	16	16	-	90	25	0,123	-	9,0	АНХ1004
BFW-018090-Z02-06-016090	2	18	16	-	90	23	0,125	-	9,0	АНХ1004
BFW-020090-Z02-06-020100	2	20	20	-	100	30	0,210	-	9,0	АНХ1004
BFW-020090-Z03-06-020100	3	20	20	-	100	30	0,206	-	9,0	АНХ1004
BFW-025090-Z02-06-025115	2	25	25	-	115	35	0,391	-	9,0	АНХ1004
BFW-025090-Z03-06-025115	3	25	25	-	115	35	0,387	-	9,0	АНХ1004
BFW-032090-Z03-06-032125	3	32	32	-	125	40	0,701	-	9,0	АНХ1004
BFW-032090-Z04-06-032125	4	32	32	-	125	40	0,698	-	9,0	АНХ1004
BFW-040090-Z04-07-032130	4	40	32	-	130	40	0,780	-	9,0	АНХ1004
BFW-040090-Z05-07-032130	5	40	32	-	130	40	0,777	-	9,0	АНХ1004
BFA-040090-Z04-07-016040	4	40	16	32	40	-	0,209	A	9,0	АНХ1004
BFA-040090-Z05-07-016040	5	40	16	32	40	-	0,207	A	9,0	АНХ1004
BFA-050090-Z05-07-022040	5	50	22	42	40	-	0,345	A	9,0	АНХ1004
BFA-050090-Z07-07-022040	7	50	22	42	40	-	0,335	A	9,0	АНХ1004
BFA-063090-Z07-07-022040	7	63	22	52	40	-	0,552	A	9,0	АНХ1004
BFA-063090-Z09-07-022040	9	63	22	52	40	-	0,541	A	9,0	АНХ1004
BFA-080090-Z08-07-027050	8	80	27	60	50	-	1,005	B	9,0	АНХ1004
BFA-080090-Z10-07-027050	10	80	27	60	50	-	0,993	B	9,0	АНХ1004
BFA-010090-Z09-07-032050	9	100	32	80	50	-	1,803	B	9,0	АНХ1004
BFA-010090-Z12-07-032050	12	100	32	80	50	-	1,784	B	9,0	АНХ1004

* **имеем возможность производства фрез под аналогичные пластины любых марок.**

* **we can design and produce mills for any insert type and brand.**

090SP12

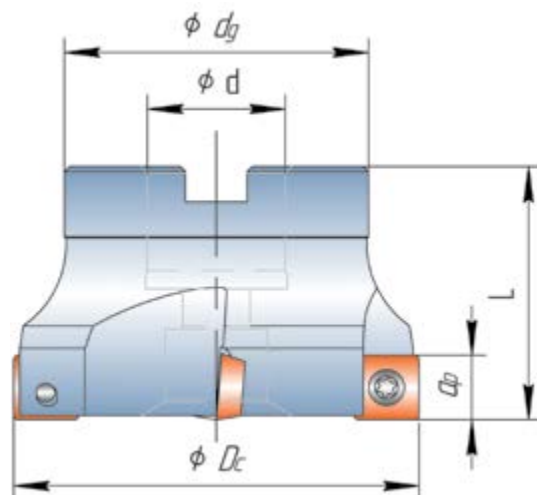

Наименование Name	Кол-во зубьев Number of teeth	Габариты Dimensions					Вес, kg Weight, kg	Тип оправки Mounting	ar, mm	Режущая пластина* Cutting insert*
		$\square Dc$	$\square Dc2$	$\square d$	$\square dg$	L				
BFA-040090-Z03-06-N016040	3	40	16	39	40		0,200	A	11	SP...T/W1204
BFA-050090-Z04-06-N022040	4	50	22	49	40		0,350	A	11	SP...T/W1204
BFA-063090-Z05-06-N027050	5	63	27	60	50		0,700	A	11	SP...T/W1204
BFA-080090-Z06-06-N027050	6	80	27	64	50		1,150	A	11	SP...T/W1204
BFA-010090-Z08-06-N032050	8	100	32	78	50		1,750	A	11	SP...T/W1204
BFA-125090-Z08-06-N040063	8	125	40	96	63		3,050	B	11	SP...T/W1204
BFA-160090-Z10-06-N040063	10	160	40	100	63		4,200	C	11	SP...T/W1204

* **имеем возможность производства фрез под аналогичные пластины любых марок.**

* **we can design and produce mills for any insert type and brand.**

045SP12

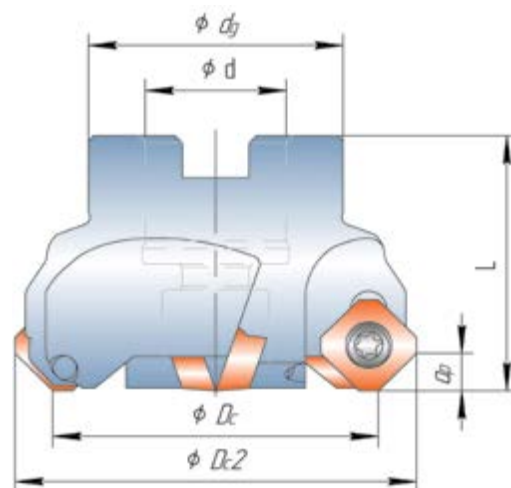

Наименование Name	Кол-во зубьев Number of teeth	Габариты Dimensions					Вес, kg Weight, kg	Тип оправки Mounting	ar, mm	Режущая пластина* Cutting insert*
		$\square Dc$	$\square Dc2$	$\square d$	$\square dg$	L				
BFA-050045-Z04-19-N022040	4	50	62	22	42	40	0,350	A	6	SP...T/W1204
BFA-063045-Z05-19-N022050	5	63	75	22	42	50	0,800	A	6	SP...T/W1204
BFA-080045-Z06-19-N027050	6	80	92	27	50	50	1,150	A	6	SP...T/W1204
BFA-100045-Z06-19-N032050	6	100	112	32	64	50	1,700	A	6	SP...T/W1204
BFA-125045-Z07-19-N040063	7	125	132	40	85	63	2,750	B	6	SP...T/W1204
BFA-160045-Z08-19-N040063	8	160	172	40	100	63	4,600	C	6	SP...T/W1204

* **имеем возможность производства фрез под аналогичные пластины любых марок.**

* **we can design and produce mills for any insert type and brand.**

060WN12

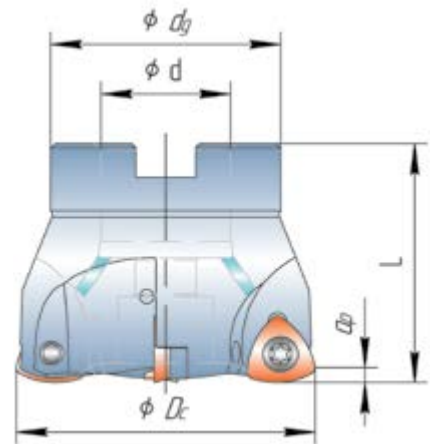

Наименование Name	Кол-во зубьев Number of teeth	Габариты Dimensions					Вес, kg Weight, kg	Тип оправки Mounting	ar, mm	Режущая пластина* Cutting insert*
		$\square Dc$	$\square Dc2$	$\square d$	$\square dg$	L				
BFR-035060-Z02-M16035	2	35	M16	29	35		0,180	-	1,8	WN...1207
BFA-052060-Z03-022045	3	52	22	40	45		0,340	A	1,8	WN...1207
BFA-063060-Z04-027050	4	63	27	48	50		0,560	A	1,8	WN...1207
BFA-066060-Z04-027050	4	66	27	48	50		0,620	A	1,8	WN...1207
BFA-066060-Z05-027050	5	66	27	48	50		0,620	A	1,8	WN...1207
BFA-080060-Z05-027050	5	80	27	60	50		1,010	A	1,8	WN...1207

* имеем возможность производства фрез под аналогичные пластины любых марок.

* we can design and produce mills for any insert type and brand.

090LN15

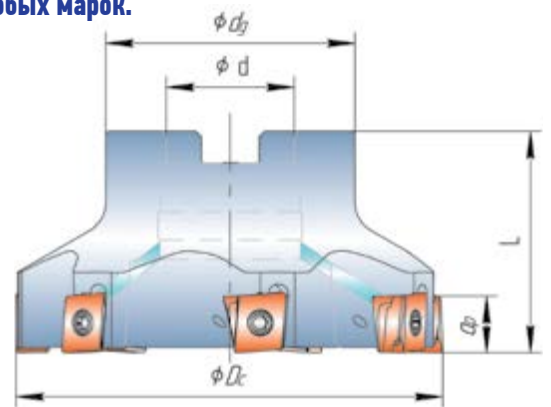

Наименование Name	Кол-во зубьев Number of teeth	Габариты Dimensions					Вес, kg Weight, kg	Тип оправки Mounting	ar, mm	Режущая пластина* Cutting insert*
		$\square Dc$	$\square Dc2$	$\square d$	$\square dg$	L				
BFA-050090-Z05-05-022040	5	50	22	42	40		0,330	A	14	LNXT1506
BFA-063090-Z05-05-022040	5	63	22	52	40		0,540	A	14	LNXT1506
BFA-063090-Z08-05-022040	8	63	22	52	40		0,570	A	14	LNXT1506
BFA-080090-Z07-05-027050	7	80	27	60	50		0,940	B	14	LNXT1506
BFA-080090-Z10-05-027050	10	80	27	60	50		0,960	B	14	LNXT1506
BFA-100090-Z08-05-032050	8	100	32	80	50		1,620	B	14	LNXT1506
BFA-100090-Z12-05-032050	12	100	32	80	50		1,700	B	14	LNXT1506
BFA-125090-Z09-05-040063	9	125	40	90	63		1,030	B	14	LNXT1506
BFA-125090-Z15-05-040063	15	125	40	90	63		0,140	B	14	LNXT1506
BFA-160090-Z10-05-N040063	10	160	40	110	63		4,400	C	14	LNXT1506
BFA-160090-Z20-05-N040063	20	160	40	110	63		4,620	C	14	LNXT1506

* имеем возможность производства фрез под аналогичные пластины любых марок.

* we can design and produce mills for any insert type and brand.

090AP10

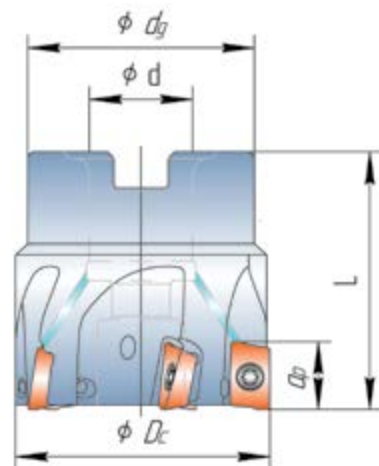

Наименование Name	Кол-во зубьев Number of teeth	Габариты Dimensions					Вес, kg Weight, kg	Тип оправки Mounting	ar, mm	Режущая пластина* Cutting insert*
		$\square Dc$	$\square Dc2$	$\square d$	$\square dg$	L				
BFW-016090-Z02-07-016085	2	16	16	-	85	26	0,110	-	9	AP...1003
BFW-016090-Z02-07-016150	2	16	16	-	150	26	0,210	-	9	AP...1003
BFW-020090-Z03-09-020090	3	20	20	-	90	28	0,190	-	9	AP...1003
BFW-020090-Z03-09-020150	3	20	20	-	150	28	0,320	-	9	AP...1003
BFW-025090-Z04-09-020150	4	25	20	-	150	26	0,340	-	9	AP...1003
BFW-025090-Z04-09-025095	4	25	25	-	95	30	0,310	-	9	AP...1003
BFR-016090-Z02-07-M08025	2	16	M8	13	25	-	0,030	-	9	AP...1003
BFR-020090-Z03-09-M10030	3	20	M10	18	30	-	0,058	-	9	AP...1003
BFR-025090-Z04-09-M12035	4	25	M12	21	35	-	0,110	-	9	AP...1003
BFA-040090-Z06-09-022040	6	40	22	39	40	-	0,210	A	9	AP...1003
BFA-050090-Z07-09-022040	7	50	22	40	40	-	0,320	A	9	AP...1003
BFA-063090-Z08-09-022040	8	63	22	48	40	-	0,560	A	9	AP...1003

* **имеем возможность производства фрез под аналогичные пластины любых марок.**

* **we can design and produce mills for any insert type and brand.**

090RD16

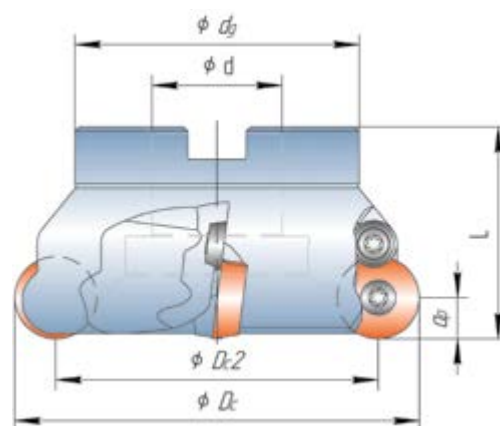

Наименование Name	Кол-во зубьев Number of teeth	Габариты Dimensions					Вес, kg Weight, kg	Тип оправки Mounting	ar, mm	Режущая пластина* Cutting insert*
		$\square Dc$	$\square Dc2$	$\square d$	$\square dg$	L				
BFA-080090-Z05-07-027050	5	80	60	27	60	50	0,840	A	10	RD...1604M0
BFA-100090-Z06-07-N032052	6	100	80	32	70	52	1,180	B	10	RD...1604M0
BFA-125090-Z07-07-N040052	7	125	105	40	90	52	2,030	B	10	RD...1604M0
BFA-160090-Z08-07-N040052	8	160	140	40	120	52	4,320	B	10	RD...1604M0

* **имеем возможность производства фрез под аналогичные пластины любых марок.**

* **we can design and produce mills for any insert type and brand.**



045SE13

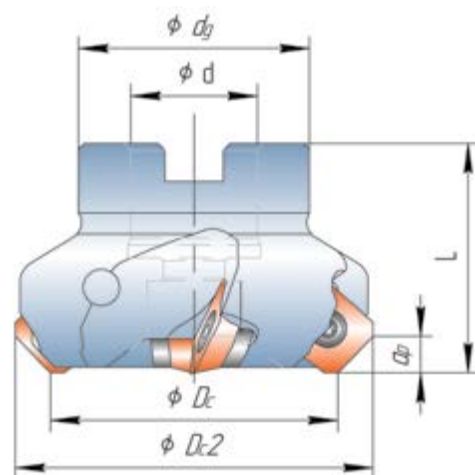

Наименование Name	Кол-во зубьев Number of teeth	Габариты Dimensions					Вес, kg Weight, kg	Тип оправки Mounting	ar, mm	Режущая пластина* Cutting insert*
		ϕDc	$\phi Dc2$	ϕd	ϕdg	L				
BFA-050045-Z04-20-N022040	4	50	63	22	40	40	0,360	A	6,0	SE...13T3
BFA-063045-Z05-21-N022040	5	63	76	22	48	40	0,590	A	6,0	SE...13T3
BFA-080045-Z06-21-N027050	6	80	93	27	60	50	1,020	B	6,0	SE...13T3
BFA-100045-Z07-21-N032050	7	100	113	32	70	50	1,520	B	6,0	SE...13T3
BFA-125045-Z08-21-N040063	8	125	138	40	90	63	3,160	B	6,0	SE...13T3
BFA-160045-Z10-21-N040063	10	160	173	40	110	63	4,610	C	6,0	SE...13T3
BFA-250045-Z24-21-N060063	24	250	263	60	172	63	13,890	C	6,0	SE...13T3

* **имеем возможность производства фрез под аналогичные пластины любых марок.**

* **we can design and produce mills for any insert type and brand.**

090A***

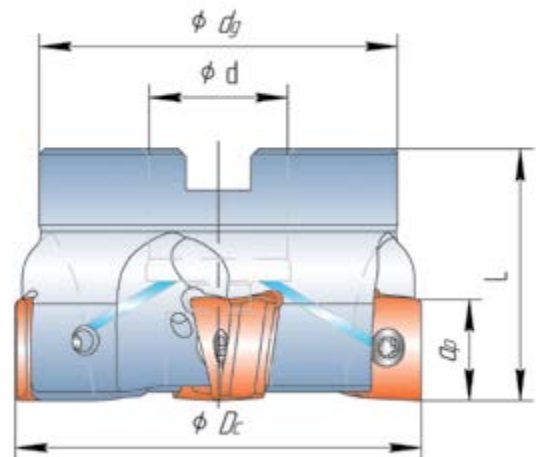

Наименование Name	Кол-во зубьев Number of teeth	Габариты Dimensions					Вес, kg Weight, kg	Тип оправки Mounting	ar, mm	Режущая пластина* Cutting insert*
		$\square D_c$	$\square D_{c2}$	$\square d$	$\square d_g$	L				
BFW-032090-Z02-04-032110	2	32	32	-	110	50	0,580	-	15	АНХ 1607
BFW-040090-Z03-04-032115	3	40	32	-	115	40	0,690	-	15	АНХ 1607
BFR-032090-Z02-04-M16043	2	32	M16	29	43	-	0,200	-	15	АНХ 1607
BFR-040090-Z03-04-M16043	3	40	M16	29	43	-	0,240	-	15	АНХ 1607
BFA-050090-Z03-04-022040	3	50	22	42	40	-	0,300	A	15	АНХ 1607
BFA-050090-Z04-04-022040	4	50	22	42	40	-	0,280	A	15	АНХ 1607
BFA-063090-Z04-04-022040	4	63	22	52	40	-	0,520	A	15	АНХ 1607
BFA-063090-Z06-04-022040	6	63	22	52	40	-	0,490	A	15	АНХ 1607
BFA-080090-Z05-04-027050	5	80	27	60	50	-	0,900	B	15	АНХ 1607
BFA-080090-Z07-04-027050	7	80	27	60	50	-	0,850	B	15	АНХ 1607
BFA-100090-Z05-04-032050	5	100	32	80	50	-	1,620	B	15	АНХ 1607
BFA-100090-Z08-04-032050	8	100	32	80	50	-	1,610	B	15	АНХ 1607
BFA-125090-Z07-04-040063	7	125	40	90	63	-	2,990	B	15	АНХ 1607
BFA-125090-Z10-04-040063	10	125	40	90	63	-	2,960	B	15	АНХ 1607
BFA-160090-Z08-04-N040063	8	160	40	110	63	-	4,360	C	15	АНХ 1607
BFA-160090-Z12-04-N040063	12	160	40	110	63	-	4,360	C	15	АНХ 1607

* **имеем возможность производства фрез под аналогичные пластины любых марок.**

* **we can design and produce mills for any insert type and brand.**



DNIPROVSKY SPECIAL TOOLS PLANT LTD

*49000, Ukraine, Dnipro
Stroiteley, 34, block 94 B
e-mail: office@dzs.com.ua
phone: +38-056-731-92-16,
+38-056-31-92-17
www.dzs.com.ua*



"TOLEX POLSKA" SP.Z.O.O.

*Poland, Reguły, gmina Michalowice, powiat Pruzskowski
Wojewodstwo Mazowieckie, al Jerozolimskie 300
e-mail: a.stawicki@tolexpolska.waw.pl
phone: 48 604 987064*